

## Miniature circuit breakers Din-Safe safety switches (RCCB)

- Standard AS/NZS 61008
- Approval No. N17482
- Accepts Din-T aux/alm switches
- Current ratings 40, 63, 80 and 100 Amps
- For use in single phase or 3 phase protection
- Handle sealable and padlockable
- DIN rail mount

DSRCD  
1 + N



**INCLUDES  
SELECTIVE TYPES**

### 2 pole modules

#### Instantaneous tripping type

Amp rating (A)	Voltage	Phase	Trip sens.	Cat. No.
40	110/240	1 + N	30 mA	DSRCD-2-40-30
			100 mA	<i>i</i> DSRCD-2-40-100
			300 mA	<i>i</i> DSRCD-2-40-300
63	110/240	1 + N	30 mA	DSRCD-2-63-30
			100 mA	DSRCD-2-63-100
80	110/240	1 + N	30 mA	DSRCD-2-80-30
			100 mA	DSRCD-2-80-100
			300 mA	<i>i</i> DSRCD-2-80-300

### Characteristics

- Type AC tripping characteristics: IEC 1008. <sup>1)</sup>
- IΔn: 30 mA, 100 mA, 300 mA and 500 mA.
- High immunity to transient currents.
- Box terminal – capacity 25 mm<sup>2</sup> to 35 mm<sup>2</sup>.
- Captive terminal screws with cross and slot head.
- Profile as per Din-T MCB.

### 2 pole modules

#### 40 ms Delayed, Selective

Inc = 10 kA MCB or fuse backup

63	110/240	1 + N	100 mA	DSRCD-2-63-100-S
			300 mA	<i>i</i> DSRCD-2-63-300-S

Connection diagram 2 pole

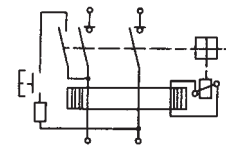

### 4 pole modules

#### Instantaneous tripping type

40	240/415	3 + N	30 mA	DSRCD-4-40-30
			100 mA	<i>i</i> DSRCD-4-40-100
			300 mA	<i>i</i> DSRCD-4-40-300
63	240/415	3 + N	30 mA	DSRCD-4-63-30
			100 mA	<i>i</i> DSRCD-4-63-100
80	240/415	3 + N	30 mA	<i>i</i> DSRCD-4-80-30
			100 mA	DSRCD-4-80-100
100	240/415	3 + N	30 mA	DSRCD-4-100-30
			100 mA	DSRCD-4-100-100
			300 mA	DSRCD-4-100-300
			500 mA	<i>i</i> DSRCD-4-100-500

Connection diagram 4 pole

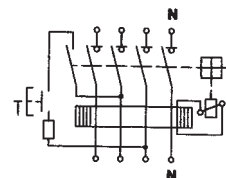

### 4 pole modules

#### 40 ms Delayed, Selective

Inc = 10 kA MCB or fuse backup

63	240/415	3 + N	100 mA	DSRCD-4-63-100-S
			300 mA	<i>i</i> DSRCD-4-63-300-S
100	240/415	3 + N	100 mA	DSRCD-4-100-100-S
			300 mA	<i>i</i> DSRCD-4-100-300-S

**Note:** The two centre poles must always be connected to the circuit for the test button function.

### Test button

The test button allows the possibility of testing the functioning of the earth-leakage detection system and tripping mechanism of the safety switch.

It is recommended that the test button be operated once a month to check the correct functioning of the safety switch.



DSRCD  
3P + N

**Notes:** <sup>1)</sup> Some type "A" RCD's are stocked. Refer NHP if required.

**Nuisance tripping may be experienced in VFD and motor starting applications refer NHP.**

*i* Available on indent only.

# Din-T RCDs Technical data

## What is an RCD?

3

The RCD (Residual Current Device) is a device intended to protect people against indirect contact, the exposed conductive parts of the installation being connected to an appropriate earth electrode. It may be used to provide protection against fire hazards due to a persistent earth fault current, without operation of the overcurrent protective device.

RCDs having a rated residual operating current not exceeding 30 mA are also used as a means for additional protection in case of failure of the protective means against electric shock (direct contact).

### Working Principle

The main components of an RCD are the following:

- The core transformer: which detects the earth fault current.
- The relay: when an earth fault current is detected, the relay reacts by tripping and opening the contacts.
- The mechanism: element to open and close the contacts either manually or automatically.
- The contacts: to open or close the main circuit.

The RCD constantly monitors the vectorial sum of the current passing through all the conductors. In normal conditions the vectorial sum is zero ( $I_1+I_2=0$ ) but in case of an earth fault, the vectorial sum differs from zero ( $I_1+I_2=I_d$ ), this causes the actuation of the relay and therefore the release of the main contacts.

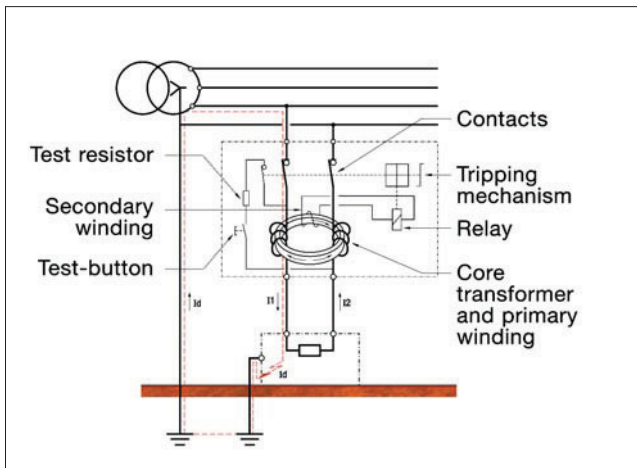

### Definitions related to RCDs

**RCCB = Residual Current Circuit Breaker without overcurrent protection.**

**RCBO = Residual Current Circuit Breaker with overcurrent protection.**

### Breaking capacity

A value of AC component of a prospective current that an RCCB is capable of breaking at a stated voltage under prescribed conditions of use and behaviour.

### Residual making and breaking capacity ( $I_{\Delta m}$ )

A value of the AC component of a residual prospective current which an RCCB can make, carry for its opening time and break under specified conditions of use and behaviour.

### Conditional residual short-circuit current ( $I_{\Delta c}$ )

A value of the AC component of a prospective current which an RCCB protected by a suitable SCPD (short-circuit protective device) in series, can withstand, under specific conditions of use and behaviour.

### Conditional short-circuit current ( $I_{nc}$ )

A value of the AC component of a residual prospective current which an RCCB protected by a suitable SCPD in series, can withstand, under specific conditions of use and behaviour.

### Residual short-circuit withstand current

Maximum value of the residual current for which the operation of the RCCB is ensured under specified conditions, and above which the device can undergo irreversible alterations.

### Prospective current

The current that would flow in the circuit, if each main current path of the RCCB and the overcurrent protective device (if any) were replaced by a conductor of negligible impedance.

### Making capacity

A value of AC component of a prospective current that an RCCB is capable to make at a stated voltage under prescribed conditions of use and behaviour.

### Open position

The position in which the predetermined clearance between open contacts in the main circuit of the RCCB is secured.

### Closed position

The position in which the predetermined continuity of the main circuit of the RCCB is secured.

### Tripping time

The time which elapses between the instant when the residual operating current is suddenly attained and the instant of arc extinction in all poles.

### Residual current ( $I_{\Delta n}$ )

Vector sum of the instantaneous values of the current flowing in the main circuit of the RCCB.

### Residual operating current

Value of residual current which causes the RCCB to operate under specified conditions.

### Rated short-circuit capacity ( $I_{cn}$ )

Is the value of the ultimate short-circuit breaking capacity assigned to the circuit breaker. (Only applicable to RCBO)

### Conventional non-tripping current ( $I_{nt}$ )

A specified value of current which the circuit breaker is capable of carrying for a specified time without tripping. (Only applicable to RCBO)

### Conventional tripping current ( $I_t$ )

A specified value of current which causes the circuit breaker to trip within a specified time. (Only applicable to RCBO)

# Din-T RCDs Technical data

## RCDs classification according to EN 61008/61009

RCDs may be classified according to:

The behaviour in the presence of DC current  
(types for general use).

- Type AC
- Type A

The time-delay (in the presence of residual current)

- RCDs without time delay: type for general use
- RCDs with time delay: type S for selectivity

### Type AC <sup>1) 2)</sup>

The type AC RCDs are designed to release with sinusoidal residual currents which occur suddenly or slowly rise in magnitude.

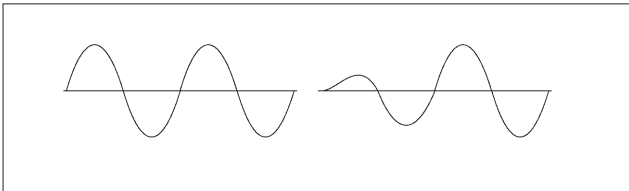

Residual current	Tripping time
$0.5 \times I\Delta n$	$t = \infty$
$1 \times I\Delta n$	$t = <300 \text{ ms}$
$2 \times I\Delta n$	$t = <150 \text{ ms}$
$5 \times I\Delta n$	$t = \leq 40 \text{ ms}$

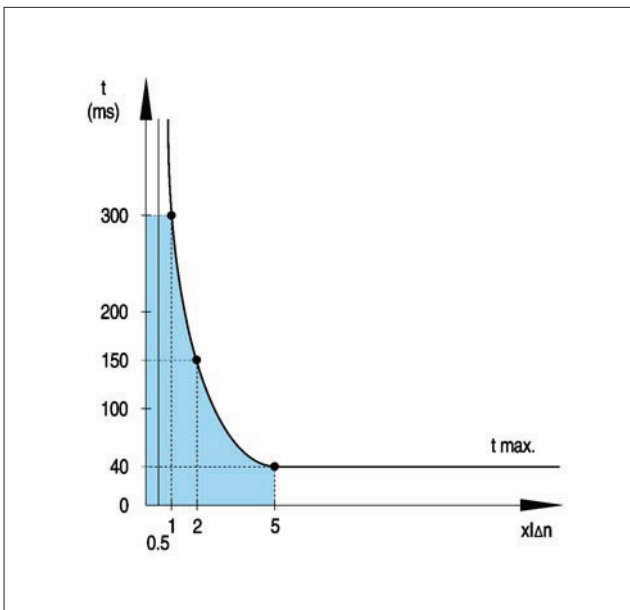

Tripping curve type AC

<sup>1)</sup> Standard in Australia

<sup>2)</sup> Type A acceptable in Australia

### Type A <sup>3) 4)</sup>

Certain devices during faults can be the source of non-sinusoidal earth leakage currents (DC components) due to the electronic components e.g. diodes, thyristors etc.

Type A RCDs are designed to ensure that under these conditions the residual current devices operate on sinusoidal residual current and also with pulsating direct current(\*) which occur suddenly or slowly rise in magnitude.

(\*) Pulsating direct current: current of pulsating wave form which assumes, in each period of the rated power frequency, the value 0 or a value not exceeding  $0.006 \text{ A DC}$  during one single interval of time, expressed in angular measure of at least  $150^\circ$ .

Residual current	Tripping time
1. For sinusoidal residual current	
$0.5 \times I\Delta n$	$t = \infty$
$1 \times I\Delta n$	$t = <300 \text{ ms}$
$2 \times I\Delta n$	$t = <150 \text{ ms}$
$5 \times I\Delta n$	$t = \leq 40 \text{ ms}$

2. For residual pulsating direct current	
At point of wave $0^\circ$	
$0.35 \times I\Delta n$	$t = \infty$
$1.4 \times I\Delta n$	$t = <300 \text{ ms}$
$2.8 \times I\Delta n$	$t = <150 \text{ ms}$
$7 \times I\Delta n$	$t = \leq 40 \text{ ms}$

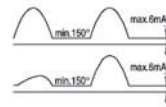

At point of wave $90^\circ$	
$0.25 \times I\Delta n$	$t = \infty$
$1.4 \times I\Delta n$	$t = <300 \text{ ms}$
$2.8 \times I\Delta n$	$t = <150 \text{ ms}$
$7 \times I\Delta n$	$t = \leq 40 \text{ ms}$

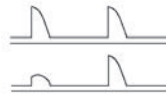

At point of wave $135^\circ$	
$0.11 \times I\Delta n$	$t = \infty$
$1.4 \times I\Delta n$	$t = <300 \text{ ms}$
$2.8 \times I\Delta n$	$t = <150 \text{ ms}$
$7 \times I\Delta n$	$t = \leq 40 \text{ ms}$

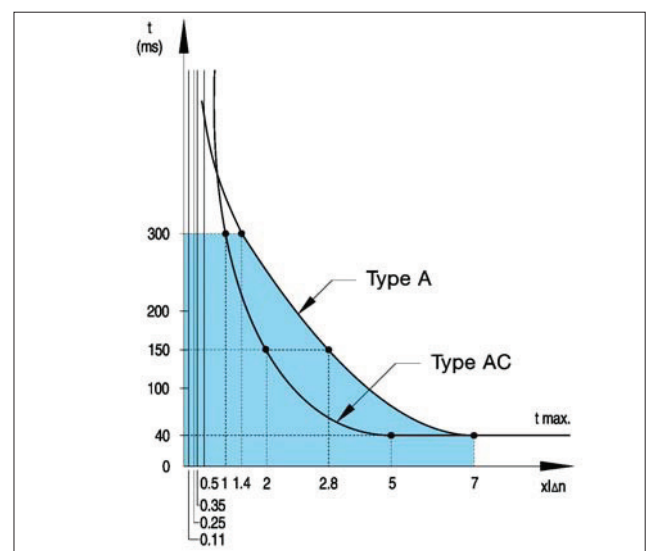

Tripping curve type A

<sup>3)</sup> Standard in New Zealand

<sup>4)</sup> DSRCBH is type A.

# Din-T RCDs Technical data

## Selectivity

3

### Type S S <sup>1)</sup>

RCDs type A or AC have instantaneous tripping. In order to provide full people protection in vertical installations with more than one circuit, as well as to ensure the service in the installation in case of earth leakage in one of the circuits, or to avoid unwanted tripping because of harmonics, high connection currents due to the use of motors, reactive loads, or variable speed drives, we need to use selective RCDs at the top of the installation.

Any RCD type S is selective to any other instantaneous RCD installed downstream with lower sensitivity.

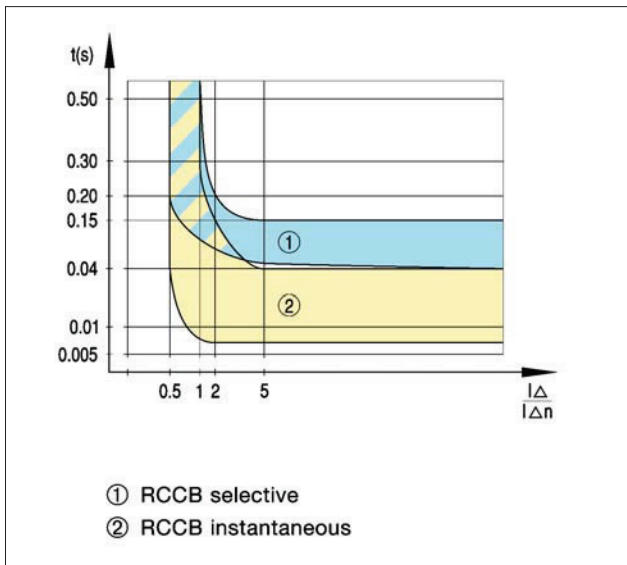

**Note:** <sup>1)</sup> DSRCD Safety switches are available as "S" types.

### Vertical selectivity

In an installation with RCDs installed in series we need to pay special attention to the vertical selectivity, in order to ensure that in case of earth leakage only, the RCD which is immediately upstream of the fault point will operate.

Selectivity is ensured when the characteristic time/current of the upstream RCD is above the characteristic time/current of the downstream RCD. To obtain vertical selectivity we should take into consideration the following parameters:

The RCD placed at the top of the installation shall be Type S. The residual operating current of the RCCB installed downstream shall have a lower residual operating current than the RCD installed upstream according to:

$$I\Delta n \text{ downstream} < I\Delta n \text{ upstream} / 3$$

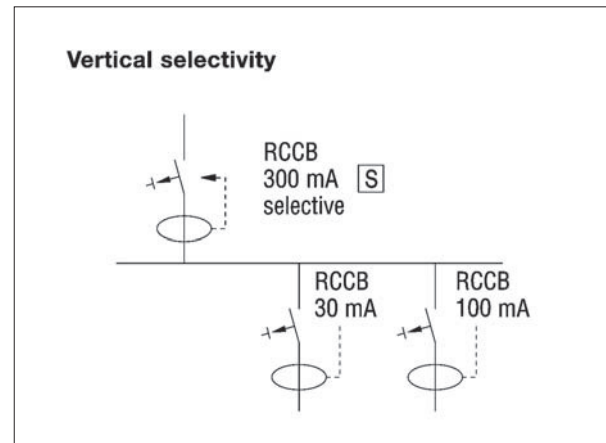

### Horizontal selectivity

To have horizontal selectivity in an installation with RCDs we need to avoid the use of RCDs in cascading. Every single circuit of the installation shall be provided with an RCD of the appropriate residual operating current. The connection between the back-up protective device and the RCD must be short-circuit protected.

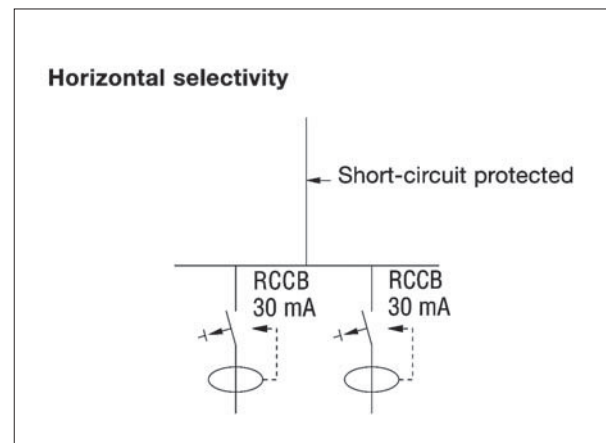

# Din-T RCDs Technical data

## Nuisance tripping

All DinSafe RCDs have a high level of immunity to transient currents, against current impulses of 8/20  $\mu$ s according to EN 61008/61009 and VDE 0664.T1.

Type A, AC.....250 A 8/20  $\mu$ s

Type S.....3000 A 8/20  $\mu$ s

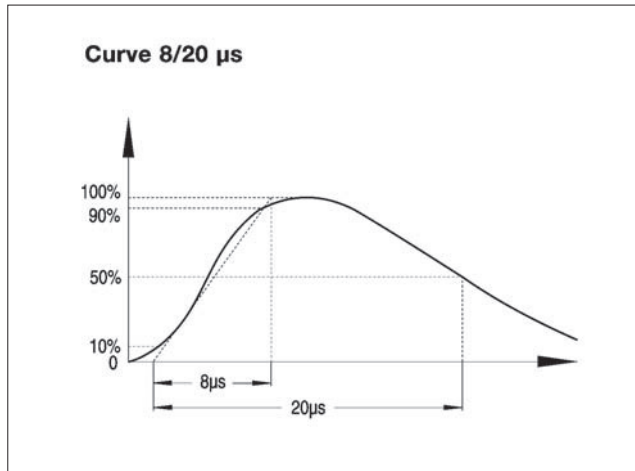

RCDs have a high level of immunity against alternating currents of high frequency according to EN 61008/61009.

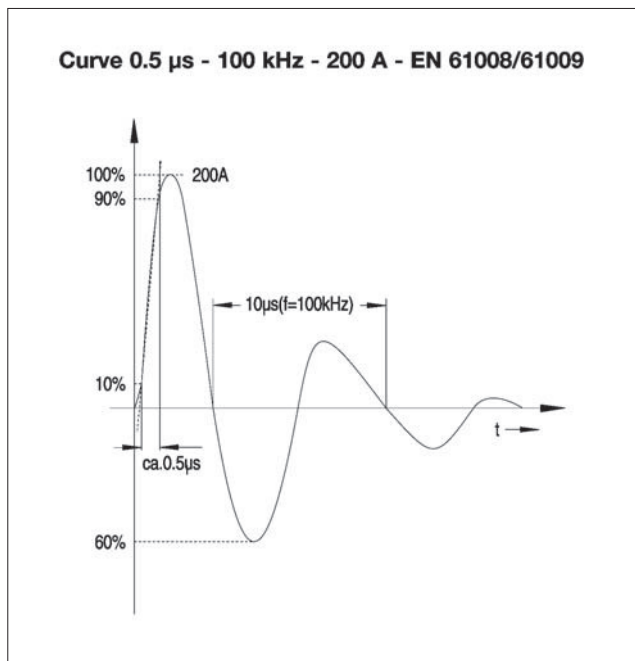

## Din-T RCDs Technical data

### RCCB type Din-Safe (DSRCD) and its use.

3

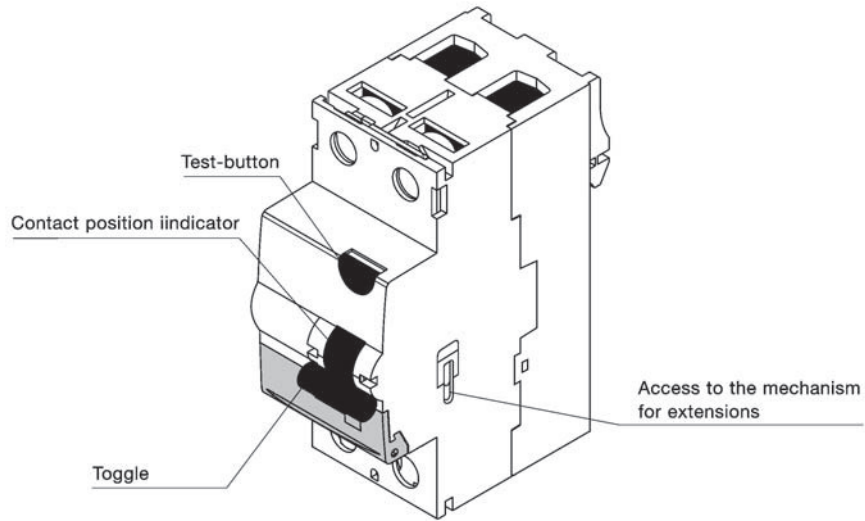

#### TEST-BUTTON

To ensure the correct functioning of the RCCB, the test button T should be pressed frequently. The device must trip when pressed.

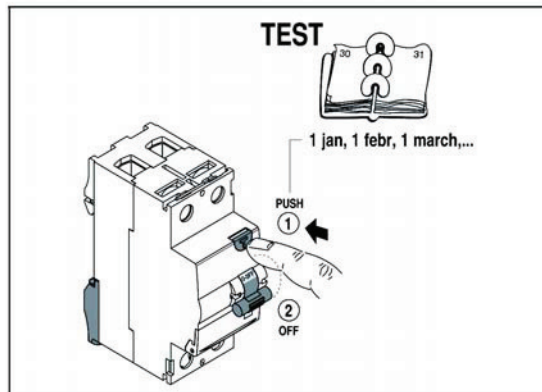

#### CONTACT POSITION INDICATOR

Printing on the toggle to provide information of the real contact position.

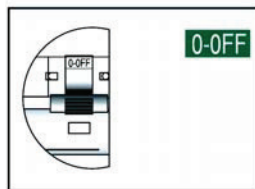

#### **O-OFF**

Contacts in open position. Ensure a distance between contacts > 4 mm.

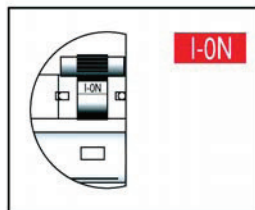

#### **I-ON**

Contacts in closed position. Ensure continuity in the main circuit.

#### TOGGLE

To switch the RCCB ON or OFF

## Din-T RCDs Technical data

### Access to the mechanism for extensions

To couple extensions we need to remove the cap on the right hand side of the breaker, in order to get access to the mechanism.

It is possible to add an auxiliary contact, shunt trip, undervoltage release or motor operator, following the stack-on configuration of the extensions in section 4.

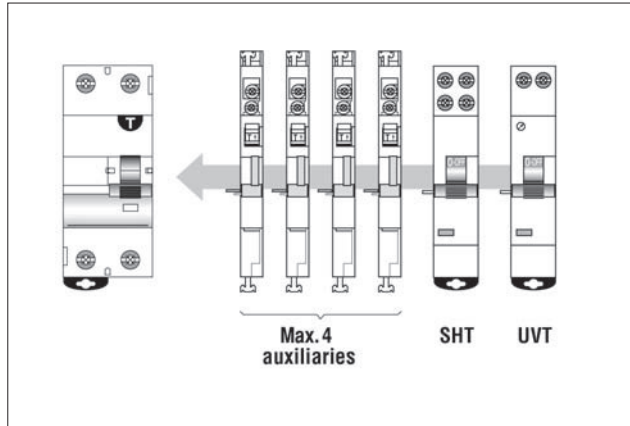

### All cables must be connected to the RCCB

All conductors, phases and neutral, that constitute the power supply of the installation to be protected, must be connected to the RCCB to either upper or lower terminals according to one of the following diagrams.

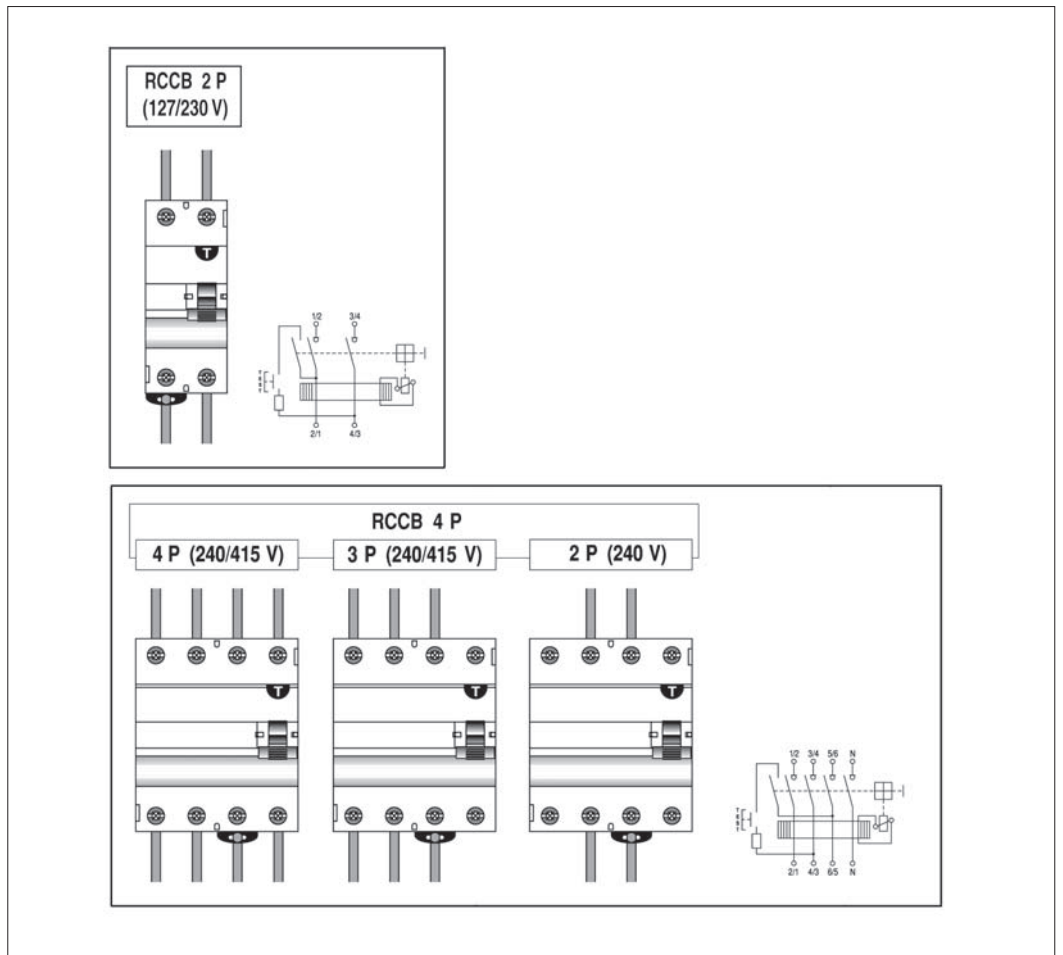

# Din-T RCDs Technical data

## Product related information

### Influence of air ambient temperature on the rated current

#### Influence of temperature on RCCB (DinSafe DSRCD)

The maximum value of the current which can flow through an RCCB depends on the nominal current as well as the ambient air temperature. The protective device placed up-stream of the RCCB must ensure disconnection at the values in the following table:

In	25 °C	30 °C	40 °C	50 °C	60 °C
16 A	19	18	16	14	13
25 A	31	28	25	23	25
40 A	48	44	40	36	32
63 A	76	69	63	57	51
80 A	97	88	80	72	65
100 A	121	110	100	90	81
125 A	151	137	125	112	101

The above-mentioned values are for devices in free air. For devices installed with other modular devices in the same switchboard, a correction coefficient (K) shall be applied in relation to the number of main circuits in the installation (EN 60439-1):

Number of devices	K
2 or 3	0.9
4 or 5	0.8
6 to 9	0.7
> 10	0.6

#### Calculation example

Within a distribution panel consisting of eight 16 A MCBs and with an operating ambient temperature of 45 °C, which is the highest temperature the MCB can operate at without unwanted tripping.

#### Calculation

The correction factor  $K = 0.7$ , for use in an eight circuit installation:  $16 \text{ A} \times 0.7 = 11.2 \text{ A}$

As the MCB is working at 45 °C another factor is applied (90 % = 0.9):

At 45 °C = In at 30 °C  $\times$  0.9 =  $11.2 \text{ A} \times 0.9 = 10.1 \text{ A}$

## Din-T RCDs Technical data

### Tripping current as a function of the frequency

All RCDs are designed to work at frequencies of 50-60 Hz, therefore to work at different values, we must consider the variation of the tripping sensitivity according to the tables below. It should be taken into consideration that there is a no tripping risk when pushing the test-button, due to the fact that such action is made by means of an internal resistor with a fixed value.

#### RCCB DSRCD safety switches <sup>3)</sup>

Type AC <sup>1)</sup>	10 Hz	30 Hz	50 Hz	100 Hz	200 Hz	300 Hz	400 Hz
30 mA	3.63	1.50	0.80	1.63	2.40	3.03	4.63
100 mA	0.75	0.74	0.80	1.18	1.69	2	2.46
300 mA	0.62	0.71	0.80	1.15	1.45	1.84	2.16
500 mA	0.80	0.72	0.80	1.15	1.52	1.79	2.12
<b>Type A</b>							
30 mA	7.57	2.40	0.75	1.63	2.53	3.70	9.23
100 mA	4.50	1.85	0.75	1.22	2.17	4.35	10.85
300 mA	3.56	1.55	0.75	1.18	2.10	4.40	17.10
500 mA	3.24	1.39	0.75	0.95	12.17	25.40	33.06

**Notes:** <sup>1)</sup> The standard NHP/Terasaki type is the "type AC" in Australia, Type "A" in New Zealand.

<sup>3)</sup> The numbers in the table above are multipliers, e.g. A "DSRCD" at 50 hz has an 0.8 multiplier.  
 Therefore a 30 mA, "type AC" RCD will trip at (0.8 x 30 mA) 24 mA.

### Power losses

The power losses are calculated by means of measuring the voltage drop between the incoming and the outgoing terminal of the device at rated current. Power loss per pole:

#### RCCB-DinSafe safety switch type DSRCD

In (A)	16	25	40	63	80	100
Z (mOhm)	9.95	3.75	2.15	1.30	1.3	0.9
Pw (W)	2.55	2.33	3.43	5.16	8.3	8.7

## Din-T RCDs Technical data

### Protection of RCCBs type DSRCD

RCCBs are not overcurrent protected. Therefore we don't need to consider both protection against short-circuits and overloads.

#### Protection against short-circuits

##### Coordination of RCCBs with MCBs or fuses, back-up protection

RCCBs protected with an SCPD have to be able to withstand, without damage, short-circuit currents up to its rated conditional short-circuit capacity. The SCPD has to be carefully selected, since the association of this device with the RCCB is interrupting the short-circuit of the installation.

The value of the presumed short-circuit current at the point where the RCCB is installed shall be lower than the values of the following table:

The RCCB and the protective device must be installed in the same switchboard, paying special attention to the connection between these two devices since, if the SCPD is installed downstream of the RCCB, such a connection must be short-circuit protected.

SCPD = Short-Circuit Protective Device.

3

#### Back-up protection with MCBs

		Din-T6	Din-T10	Din-T15	Din-T10H
<b>RCCB</b>	16 A	20 kA	20 kA	20 kA	10 kA
<b>2 Poles</b>	25 A	20 kA	20 kA	20 kA	10 kA
<b>240 V</b>	40 A	20 kA	20 kA	20 kA	10 kA
<b>(DSRCD)</b>	63 A	20 kA	20 kA	20 kA	10 kA
	80 A	-	-	-	10 kA
	100 A	-	-	-	10 kA
<b>RCCB 4 Poles</b>	25 A	10 kA	10 kA	10 kA	10 kA
<b>415 V</b>	40 A	10 kA	10 kA	10 kA	10 kA
<b>(DSRCD)</b>	63 A	10 kA	10 kA	10 kA	10 kA
	80 A	-	-	-	10 kA
	100 A	-	-	-	10 kA

#### Back-up protection with fuses gG

		16 A	25 A	32 A	40 A	50 A	63 A	80 A	100 A
<b>RCCB</b>	16 A	100 kA	100 kA	80 kA	50 kA	40 kA	25 kA	16 kA	10 kA
<b>2 Poles</b>	25 A	100 kA	100 kA	80 kA	50 kA	40 kA	25 kA	16 kA	10 kA
<b>240 V</b>	40 A	100 kA	100 kA	80 kA	50 kA	40 kA	25 kA	16 kA	10 kA
<b>(DSRCD)</b>	63 A	100 kA	100 kA	80 kA	50 kA	40 kA	25 kA	16 kA	10 kA
	80 A	100 kA	100 kA	80 kA	50 kA	40 kA	25 kA	16 kA	10 kA
	100 A	100 kA	100 kA	80 kA	50 kA	40 kA	25 kA	16 kA	10 kA
<b>RCCB</b>	25 A	100 kA	100 kA	80 kA	50 kA	40 kA	25 kA	16 kA	10 kA
<b>4 Poles</b>	40 A	100 kA	100 kA	80 kA	50 kA	40 kA	25 kA	16 kA	10 kA
<b>415 V</b>	63 A	100 kA	100 kA	80 kA	50 kA	40 kA	25 kA	16 kA	10 kA
<b>(DSRCD)</b>	80 A	100 kA	100 kA	80 kA	50 kA	40 kA	25 kA	16 kA	10 kA
	100 A	100 kA	100 kA	80 kA	50 kA	40 kA	25 kA	16 kA	10 kA

# Din-T RCDs Technical data

## Text for specifiers

### RCCB - DinSafe safety switches (DSRCD)

- According to EN 61008 standard.
- Intended to detect residual sinusoidal currents (type AC) or residual pulsating direct currents (type A).
- Resistance against nuisance tripping according to VDE 0664 T1 and EN 61008.
- Working ambient temperature from  $-25\text{ °C}$  up to  $+40\text{ °C}$  for type A and from  $-5\text{ °C}$  up to  $+40\text{ °C}$  for type AC.
- Approved by CEBC, VDE, KEMA, IMQ etc.
- The RCCB are 2 P and 3 P+N with 2 and 4 modules wide.
- The neutral pole in the 3 P+N RCCB is on the right hand side. The N pole closes first of all poles and opens last of all poles.
- Nominal rated currents are: 16, 25, 40, 63, 80 \*A.
- Nominal residual currents are: 10, 30, 100, 300, 500 mA.
- The test circuit is protected against overloads.
- All RCCBs have a minimum short-circuit resistance of 10 kA when they are back-up protected by means of MCBs or fuses.
- The making and breaking capacity is 500 A.
- The residual making and breaking capacity is 1500 A.
- Terminal capacity from 1 up to 50 mm<sup>2</sup> rigid wire or 1.5 up to 50 mm<sup>2</sup> flexible wire.
- The devices 10, 30, 100 mA type A or AC always have vertical selectivity with devices 300 mA type S.
- The selective types have a delayed tripping time in comparison with the instantaneous ones (type A, AC) with sensitivity lower than 300 mA.
- Both incoming and outgoing terminals have a protection degree of IP 20 and are sealable.
- Isolator function due to Red/Green printing on the toggle.
- Auxiliary contacts can be added on the right hand side.
- RCCBs can be released by means of a shunt trip or undervoltage release.
- RCCBs can be remotely controlled by means of a motor operator.
- RCCBs have a tripping indicator which is activated in case of automatic release only.

# Din-T MCBs + RCDs Technical data

## Overview Din-Safe RCDs

### RCCB



### Device type definition

Rating/description	Cat. No.	DSRCD SAFETY SWITCH	
Standards		IEC 61008-1	
Magnetic tripping characteristics		-	
Residual tripping characteristic <sup>1)</sup>		AC, A, S	
Tripping time at I $\Delta$ n	Instantaneous	ms	<300
	Selective	ms	>150
Rated current	A	40, 63, 80, 100	
Rated residual current I $\Delta$ n	mA	30, 100, 300, 500	
Calibration temperature	°C	30	
Number of poles versus modules		1	
Rated voltage Un	2 P AC	V	240
	3 P AC	V	-
	4 P AC	V	415
Frequency	Hz	50/60	
Maximum service voltage U <sub>bmax</sub>	V	2 P=265 / 4 P=455	
Minimum service voltage U <sub>bmin</sub>	V	2 P=110 / 4 P=190	
Power supply		Top/Bottom	
Selectivity class		-	
Rated making and breaking capacity (I <sub>m</sub> )	A	500 (or 10xI <sub>n</sub> )	
Residual making and breaking capacity (I $\Delta$ m)	A	500 (or 10xI <sub>n</sub> )	
Conditional short-circuit capacity (I <sub>nc</sub> )	A	10000 fuse 100 A	
Conditional residual short-circuit capacity (I $\Delta$ c)	A	10000	
Short-circuit capacity (I <sub>cn</sub> )	A	-	
Grid distance (safety distance between two devices)	mm	35	
Isolator application		yes	
Insulation degree	Insulation voltage	V (DC)	500
	Shock voltage (1.2/50 ms)	kV	8
	Insulation resistance	(mOhm)	1000
	Dielectric strength	V	2500
Shock resistance (in x, y, z direction)(IEC 60077/16.3)		40 g, 18 shocks 5 ms	
Vibration resistance (in x, y, z direction; IEC 60068-2-6)		1.5 g, 30 min, 0...80 Hz	
Endurance	electrical at Un, I <sub>n</sub>		10000
	mechanical at Un, I <sub>n</sub>		20000
Protection degree (outside/inside electrical enclosure)		IP 20 / IP 40	
Self extinguish degree (according to UL 94)		V2	
Tropicalisation (according to IEC 60068-2, DIN 40046)	°C/RH	+55/95 %	
Pollution degree (acc. IEC 60947-1)		3	
Operating temperature	°C	AC (-5.. +60); A -25.. +60)	
Storage temperature	°C	-25..+70	
Terminals capacity	Rigid cable min/max (Top)	mm <sup>2</sup>	1.5/50 [1.5/35]
	Flexible cable min*/max (Top)	mm <sup>2</sup>	1.5/35 [1.5/25]
	Rigid cable min/max (bottom)	mm <sup>2</sup>	1.5/50 [1.5/35]
	Flexible cable min*/max (bottom)	mm <sup>2</sup>	1.5/35 [1.5/25]
	(*Flexible cable 0.75/1/1.5 mm <sup>2</sup> with cable lug)		
Torque	Top/Bottom	Nm	5/5
Add-on devices (side add-on)	Auxiliary contacts		yes
	UVT		yes
	Shunt trip		yes
	Motor operator		yes
	Panelboard switch		yes
Busbars systems	Pin		yes
	Fork		yes
<b>Accessories</b>			
Dimensions, weights, packaging	# Poles		2-4
	(HxDxW) 86x68xW	mm	36/72
	Weight/unit	g	2 P=250 / 4 P=368
	<b>Package/unit</b>		2 P=1/6 / 4 P=1/3

**Note:** <sup>1)</sup> Refer catalogue section for types.

<sup>2)</sup> Making sure that N-L and both flying leads are disconnected.

## Din-T MCBs + RCDs Technical data

RCCB - Din-Safe safety switch (DSRCD)

Dimensions in mm

