

# Catalogue No: **D7P-SM22PX10**

## SELECTOR SW 22.5mm PLASTIC 2 POSITION WHITE 1N/O

Operator Control Devices > Pushbuttons and Control Switches > Pushbuttons and Pilot Lights > Sprecher + Schuh D7 Pushbuttons and Pilot Lights > D7 Selector and Key Selector Switches > Selector Switches Complete



Representative Photo Only  
(actual product may vary based on configuration selections)

### Rotary switch plastic 2 position maintained 1N/O

- D7 pilot devices offer maximum flexibility and a wide choice for all 22.5mm operator applications with all type (e-stops, selector switches, pushbuttons, pilot lights and more), colour and contact configurations.
- Aesthetically appealing and modularly designed to make assembly and interchangeability easy.
- Operators exhibit low profile and stylish appearance while maintaining the rugged performance necessary for demanding environments
- D7P is a plastic operator with a captive black plastic front bezel. Constructed of high-grade thermoplastics, the D7P is suitable for almost all environments and strong chemical resistance.
- D7M has a die-cast zinc housing and mounting ring for rugged durability. Finished with corrosion resistant chrome plating, the D7M also features a captive shiny metal bezel for a polished appearance.

### SPECIFICATIONS

Component Type Pushbutton and Pilot Lights	Selector Switch
Operator Type	Selector Switch, Short Handle, 2-Position type
Operator Positions (from Vertical)	30° -30°
Key	No Y / N
Operator Action, Left	Latched / Maintained
Operator Action, Right	Latched / Maintained
Colour, Operator	Black Colour
Material, Operator	TP (Thermoplastic)
Colour, Operator Insert	White
Material, Bezel	Glass-Filled Nylon / PA6 / PA66 (Polyamide 6)
Coupling Plate Included	Yes
Material, Latches	Glass-Filled Nylon / PA6 / PA66 (Polyamide 6)
Mounting	22.5mm Mounting Hole
Contact Block Included	Yes
Contact Configuration	1 NO
Ie, Rated Operational Current, AC 1, 240V AC	10 A @240V
Ie, Rated Operational Current, AC 15, 110-120V AC	6 A
Ie, Rated Operational Current, AC 15, 240V AC	3 A
Ie, Rated Operational Current, AC 15, 415V AC	2.2 A
Ui, Rated Insulation Voltage	690 V (rms)
Compatible Product Series	D7 22.5mm Control & Indication compatible
Material, Contacts	Silver Nickel (AgNi) material
Terminal Type	Screw Terminal(s)
Material, Terminal	Brass
Tightening Torque, Min	0.7 Nm
Tightening Torque, Max	0.9 Nm

# Catalogue No: **D7P-SM22PX10**

## SELECTOR SW 22.5mm PLASTIC 2 POSITION WHITE 1N/O

Operator Control Devices > Pushbuttons and Control Switches > Pushbuttons and Pilot Lights > Sprecher + Schuh D7 Pushbuttons and Pilot Lights > D7 Selector and Key Selector Switches > Selector Switches Complete



Material, Spring	Zinc-Plated Stainless Steel
Ith, Thermal Current, Open	10 A
Wire / Conductor Size (Min)	0.75 mm <sup>2</sup>
Wire / Conductor Size (Max)	2.5 mm <sup>2</sup>
Dielectric Strength	2.5kV for 1 minute
Recommended Fuse Current Rating	10 A
Fuse Characteristic Type(s)	IEC-gL/gG
Tightening Torque, Nominal	1.7 Nm
Mechanical service life	300000 cycles
RoHS Approved	Yes
CE Marked	Yes
Operating Temperature, Max	70 °C max
Operating Temperature, min	-25 °C min
Storage Temperature, max	85 °C max
Storage Temperature, min	-40 °C min
Relative humidity, min	50 %RH
Relative humidity, max	95 %RH
IP Rating	IP66 IP65
Shock Acceleration (Max.)	100 g
Shock Duration (Max.)	11 ms
Vibration Acceleration (Max.)	10 g
Vibration Displacement (Peak to Peak Max.)	1.52 mm
Vibration Frequency, Operational (Max.)	2000 Hz
Vibration Duration (Max.)	180 min
Standards Compliance	NEMA ICS-5 UL 508 EN 60947-1 EN 60947-5-1 EN 60947-5-5 EN 418
Certifications	UL UR CSA CCC CE
Shipping Approvals	RINA (Registro Italiano Navale) ABS (American Bureau of Shipping) Lloyd's Register of Shipping

### REFERENCES

IECEX Certificate	-
Supplier Declaration of Conformity:	-
Installation Guide:	-
User Manual:	-
Manufacturer Datasheet:	<a href="#">Series D7_Manufacturer Datasheet</a>
Manufacturer Catalogue & Product Selection:	-

Catalogue No: **D7P-SM22PX10**

**SELECTOR SW 22.5mm PLASTIC 2 POSITION WHITE 1N/O**

Operator Control Devices > Pushbuttons and Control Switches > Pushbuttons and Pilot Lights > Sprecher + Schuh D7  
Pushbuttons and Pilot Lights > D7 Selector and Key Selector Switches > Selector Switches Complete

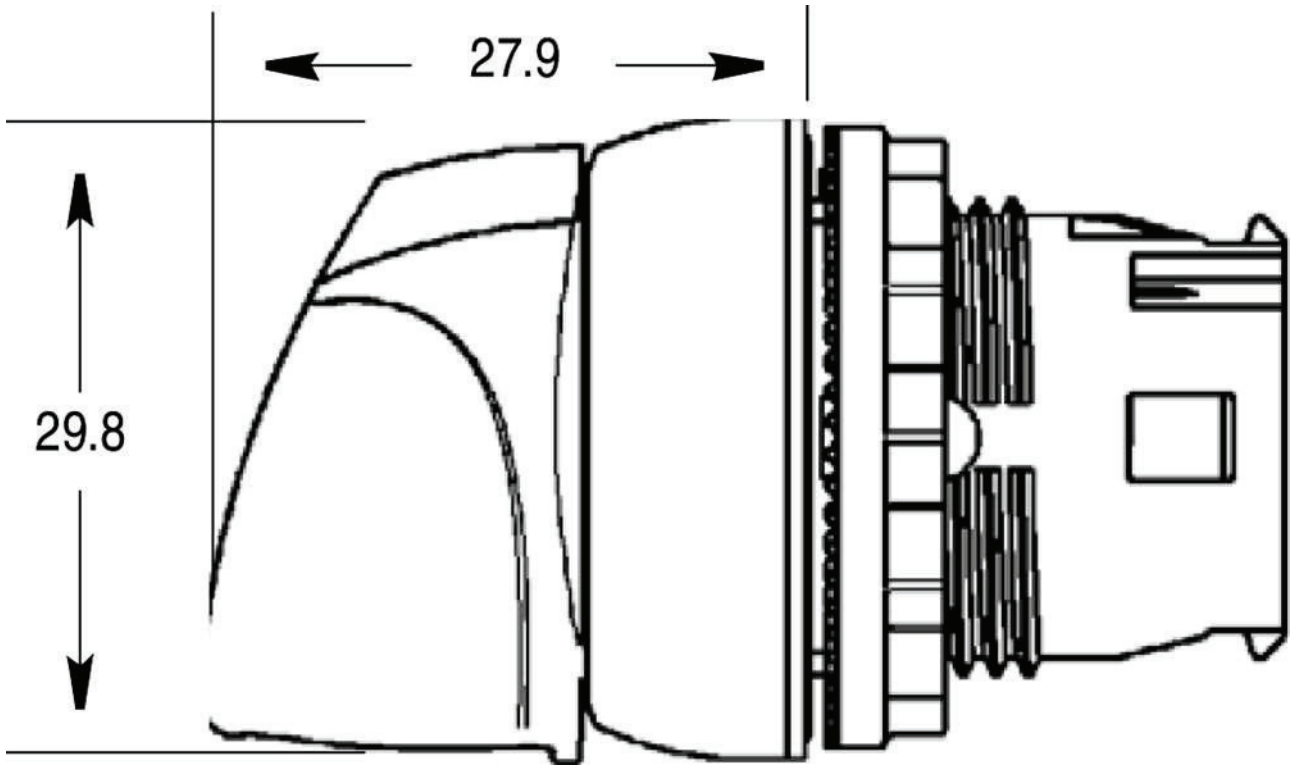

Dimension Diagram