

EVOLUTION DISTRIBUTION BOARD - STANDARD

E65A72T250/ E65A84T250

STANDARDS:

- Compliant to AS/NZS 61439.2 & AS/NZS 61439.3
- Tested to $I_n A = 250A @ RDF$ of 0.6
- Conditional Withstand Rating: Tested to 30kA

CONSTRUCTION:

- Enclosure Dimensions (Height x Width x Depth): 1200mm x 600mm x 200mm
- E65 IP65 is rate tested to AS60529-2004 by UL certificate 129169-02/A1
- 1.6mm Mild steel Shell, partially welded construction
- Colour RAL2000 (Orange)
- Continuous machine-injected polyurethane gasket
- Door hinge: mild steel 1 fixed pin and additional hinges are spring release
- Paint is epoxy polyester powder, semi-gloss 50-70%, 60-80 micron & cured at 180 °C
- Twin gland plate with polyurethane gasket
- Standard with 3 IEC steel locks
- Mounting plate: Aluminium Zinc 2mm
- Escutcheon: 2.0mm Mild Steel, colour RAL9010 (White)



Illustration purpose only

CHASSIS

- Current Rating: 250A
- Base 1.5mm sheet steel
- Copper: 2mm thick for 250A chassis
- Withstand rating: Tested to 25kA/0.1s and 10kA/1s
- Number of Poles (18mm Pitch): 72/ 84

MAIN SWITCH

- IPD Main switch 250A 690Vac rated ABB load break switch
- Withstand Rating: Tested to 15kA/0.25s and 8kA/1s

SUPPORT SYSTEM

- Pillars are 14mm A/F bright mild steel bar
- Z15 Fe/Zn 8cC (Dichromate passivation)

EARTH AND NEUTRAL BARS

- 330A Dual Bars
- Bar cross section: 10mm x 20mm
- Tunnel terminal: 6mm (16mm² conductor)
- Double feeder fixing M6
- 250A rated copper link, neutral link DURAVIN coated

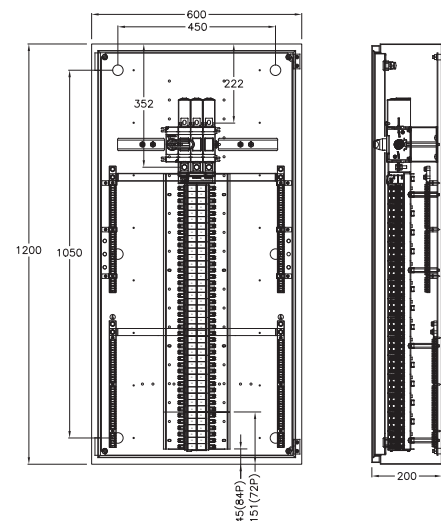

Up to 84P*

*84P model shown