

233

True-rms Remote Display Digital Multimeter

Calibration Information

Introduction

⚠ ⚠ Warning

To avoid electric shock or injury, do not perform the performance tests or calibration adjustment procedures unless qualified to do so.

The information provided in this document is for the use of qualified personnel only.

The *233 Calibration Information* provides the information necessary to adjust and verify the performance of the Fluke Model 233 True-rms Remote Display Digital Multimeter (hereafter known as the Meter).

The following information is included in this document:

- Safety Information and International Electrical Symbols (page 2)
- Specifications (page 3)
- Testing the Fuse (page 9)
- Replacing the Fuse and the Battery (page 10)
- Cleaning (page 10)
- Performance Tests (page 11)
- Calibration Adjustment (page 14)
- Replacement Parts and Accessories (page 19)
- Complete Warranty (page 21)

See the *233 Users Manual* for complete operating instructions.

Contact Information

To contact Fluke, call one of the following telephone numbers:

USA: 1-888-99-FLUKE (1-888-993-5853)

Canada: 1-800-36-FLUKE (1-800-363-5853)

Europe: +31 402-675-200

Japan: +81-3-3434-0181

Singapore: +65-738-5655

Anywhere in the world: +1-425-446-5500

Or, visit Fluke's Website at www.fluke.com.

To register your product, visit register.fluke.com

To see, print, or download the latest manual supplement, visit <http://us.fluke.com/usen/support/manuals>.

Safety Information

A **Warning** identifies hazardous conditions and actions that could cause bodily harm or death.

A **Caution** identifies conditions and actions that could damage the Meter, the equipment under test, or cause permanent loss of data.

Warning

To prevent possible electrical shock or personal injury, follow these guidelines:

- Use this Meter only as specified in this manual or the protection can be compromised.
- Do not use the Meter if it is damaged. Before you use the Meter, examine the case. Look for cracks or missing plastic. Carefully look at the insulation around the terminals.
- Make sure the battery door is closed and locked before you operate the Meter.
- Replace the batteries when the battery indicator () appears.
- Remove the test leads from the Meter before the battery door on the Meter base is opened.
- Examine the test leads for damaged insulation or exposed metal. Measure the test leads for continuity. Do not use if resistance is high or noisy. Replace damaged test leads before you use the Meter.
- Do not apply more than the rated voltage, shown on the Meter, between the terminals or between a terminal and earth ground.
- Do not operate the Meter with the battery door removed or the case open.
- Be careful around voltages >30 V ac rms, 42 V ac peak, or 60 V dc. These voltages pose a shock hazard.
- Use only the replacement fuse specified by the manual.
- Use the correct terminals, function, and range for measurements.
- Do not work alone.
- For current measurements, connect the Meter to the circuit after you remove circuit power. Always put the Meter in series with the circuit.
- Connect the common test lead before the live test lead and remove the live test lead before the common test lead.
- Do not use the Meter if it operates incorrectly. Protection can be compromised. If you are unsure, have the Meter examined.
- Do not use the Meter around explosive gas, vapor or in damp or wet environments.
- Use only specified 1.5-V AA batteries (three in the Meter base and two in the display), correctly installed, for Meter power.
- Comply with local and national safety requirements when in hazardous locations.
- Only use test leads that have the same voltage, category, and amperage ratings as the Meter and that are approved by a safety agency.
- Measure a known voltage first to make sure that the Meter operates correctly. If you are unsure, have the Meter examined.
- Use protective equipment, as directed by local or national authorities when in hazardous work areas.
- Use only specified replacement parts in the Meter.
- Keep fingers behind the finger guards on the probes.

⚠ Caution

To prevent damage to the Meter or to the equipment under test, follow these guidelines:

- **Disconnect circuit power and discharge all high-voltage capacitors before you do diode tests or measure resistance, continuity, or capacitance.**
- **Use the correct terminals, function, and range for all measurements.**
- **Before a current measurement, do the fuse test.**

International Electrical Symbols

Table 1 lists the international symbols that appear in this document and on the Meter.

Table 1. Electrical Symbols

~	AC (Alternating Current)		Earth ground
—	DC (Direct Current)		Fuse
	Hazardous voltage	CE	Conforms to European Union directives.
	Risk of Danger. Important information. See Manual.		Conforms to relevant Canadian Standards Association directives.
	Battery. Low battery when shown.		Double insulated
)))	Continuity test or continuity beeper tone.		Capacitance
CAT III	IEC Measurement Category III CAT III equipment has protection against transients in equipment in fixed-equipment installations, such as distribution panels, feeders and short branch circuits, and lighting systems in large buildings.	CAT IV	IEC Measurement Category IV CAT IV equipment has protection against transients from the primary supply level, such as an electricity meter or an overhead or underground utility service.
	Do not discard this product as unsorted municipal waste. Go to the Fluke website for recycling data.		Diode
	Examined and licensed by TÜV Product Services.		Conforms to relevant Australian standards.

General Specifications

Maximum voltage between any

terminal and earth ground 1000 V rms

⚠ Fuse for A inputs 11 A, 1000 V 17000A interrupt rating Fuse

Display 6000 counts, updates 4/sec (Frequency: 9,999 counts, Capacitance: 1,000 counts)

Altitude

Operating 2,000 meters

Storage 12,000 meters

Temperature

Operating -10 °C to +50 °C

Storage -40 °C to +60 °C

Temperature coefficient 0.1 X (specified accuracy) / °C (< 18 °C or > 28 °C)

Electromagnetic Compatibility (EN 61326-1:2006) In an RF field of 3 V/m, accuracy = specified accuracy except in temperature: specified accuracy ±5 °C (9 °F)

Wireless Frequency 2.4 GHz ISM Band 10 meter range

Relative Humidity	Maximum noncondensing 90 % at 35 °C 75 % at 40 °C 45 % at 50 °C 0 % to 70 % for 40 MΩ range
Battery Type	
Meter base.....	Three AA Alkaline batteries, NEDA 15A IEC LR6
Display module	Two AA Alkaline batteries, NEDA 15A IEC LR6
Battery Life	400 hrs typical (Alkaline)
Shock	1 Meter drop 6 sides per IEC 61010
Size (H x W x L)	5.3 cm x 9.3 cm x 19.3 cm
Weight	604 g (1.3 lbs)
Safety Compliance	Complies with ANSI/ISA S82.01-2004, CSA 22.2 No. 61010-1-04 to 1000 V Measurement Category III and 600 V Measurement Category IV.
Certifications	CSA, TÜV (EN61010), CE,  (N10140), VDE, GOST

Detailed Specifications

For all detailed specifications:

Accuracy is specified for 1 yr after calibration, at operating temperatures of 18 °C to 28 °C, with relative humidity at 0 % to 90 %. Accuracy specifications take the form of \pm (% of Reading) + [Number of least significant digits].

AC Voltage

AC conversions are ac-coupled and valid from 1 % to 100 % of range.

Range ^[1]	Resolution	Accuracy	
		45 – 500 Hz	500 Hz – 1 kHz
600.0 mV	0.1 mV	$\pm(1.0 \% + 3)$	$\pm(2.0 \% + 3)$
6.000 V	0.001 V		
60.00 V	0.01 V		
600.0 V	0.1 V		
1000 V	1 V		

[1] Crest factor of ≤ 3 at 4000 counts, decreasing linearly to 1.5 at full scale.

DC Voltage, Conductance, and Resistance

Function	Range	Resolution	Accuracy
mV dc	600.0 mV	0.1 mV	$\pm(0.25 \% + 2)$
V dc	6.000 V	0.001 V	
	60.00 V	0.01 V	
	600.0 V	0.1 V	
	1000 V	1 V	
Ω	600.0 Ω	0.1 Ω	$\pm(0.9 \% + 2)$
	6.000 kΩ	0.001 kΩ	$\pm(0.9 \% + 1)$
	60.00 kΩ	0.01 kΩ	
	600.0 kΩ	0.1 kΩ	
	6.000 MΩ	0.001 MΩ	
	40.00 MΩ	0.01 MΩ	$\pm(1.5 \% + 2)$

Continuity

The beeper is guaranteed on $<20 \Omega$, and guaranteed off $>250 \Omega$, and detects opens or shorts of 500 μs or longer.

Temperature

Range	Resolution	Accuracy ^[1]
-40 °C to +400 °C	0.1 °C	±(1.0 % + 10)
-40 °F to +752 °F	0.1 °F	±(1.0 % + 18)

[1] Temperature uncertainty (accuracy) does not include error of the thermocouple probe.

AC Current

Function	Range	Resolution	Accuracy (45 – 500 Hz)
A ac ^[1,2,3]	6.000 A	0.001 A	±(1.5 % + 3)
	10.00 A	0.01 A	

[1] All ranges are specified from 5 % of range to 100 % of range.
 [2] Crest factor of ≤3 at 4000 counts, decreasing linearly to 1.5 at full scale.
 [3] AC current >10 A is unspecified. 20 A continuous overload for 30 seconds maximum.

DC Current

Function	Range	Resolution	Accuracy
A dc ^[1]	6.000 A	0.001 A	±(1.0 % + 3)
	10.00 A	0.01 A	

[1] DC current >10 A is unspecified. 20 A continuous overload for 30 seconds maximum.

Capacitance

Range	Resolution	Accuracy
1000 nF	1 nF	±(1.9 % + 2) ^[1]
10.00 μF	0.01 μF	
100.0 μF	0.1 μF	
9999 μF	1 μF	

[1] >1000 μF: 5 % + 20

Diode

Range	Resolution	Accuracy
2.000 V	0.001 V	±(0.9 % + 2)

Frequency

AC coupled, 5 Hz to 50 kHz, for V ac; dc coupled, 45 Hz to 5 kHz for A ac switch position.

Range	Resolution	Accuracy
99.99 Hz	0.01 Hz	±(0.1 % + 2)
999.9 Hz	0.1 Hz	
9.999 kHz	0.001 kHz	
50.00 kHz	0.01 kHz	

Input Characteristics

Function	Overload Protection	Input Impedance (nominal)	Common Mode Rejection Ratio (1 k Ω unbalance)		Normal Mode Rejection
\bar{V}	1100 V rms	>10 M Ω <100 pF	> 100 dB at dc, 50 Hz or 60 Hz		> 60 dB at 50 Hz or 60 Hz
\tilde{V}	1100 V rms	>5 M Ω < 100 pF	> 60 dB, dc to 60 Hz		
		Open Circuit Test Voltage	Full Scale Voltage		Typical Short Circuit Current
			To 6 M Ω	40 M Ω	
Ω	1100 V rms	<2.7 V dc	<0.7 V dc	<0.9 V dc	<350 μ A
μ)	1100 V rms	<2.7 V dc	<300 mV dc		<350 μ A
+	1100 V rms	<2.7 V dc	<700 mV dc		<350 μ A
+	1100 V rms	<2.7 V dc	Up to 2.000 V dc		1.2 mA

MIN MAX Recording

Nominal Response	Accuracy
100 ms to 80 %	Specified accuracy \pm 12 counts for changes >200 ms in duration (\pm 40 counts in ac)

Battery Replacement

⚠ ⚠ Warning

To prevent incorrect measurements, possible electrical shock, or personal injury, replace the battery when the battery indicator (🔋) appears. If the display shows `bAtE d ISP`, the Meter will not function until the display module batteries are replaced. If the display shows `bAtE bA5E`, the Meter will not function until the Meter-base batteries are replaced.

There are two low-battery indicators in the display: one for the Meter base batteries and one for the display module batteries. Replace the batteries when the low-battery indicator shows.

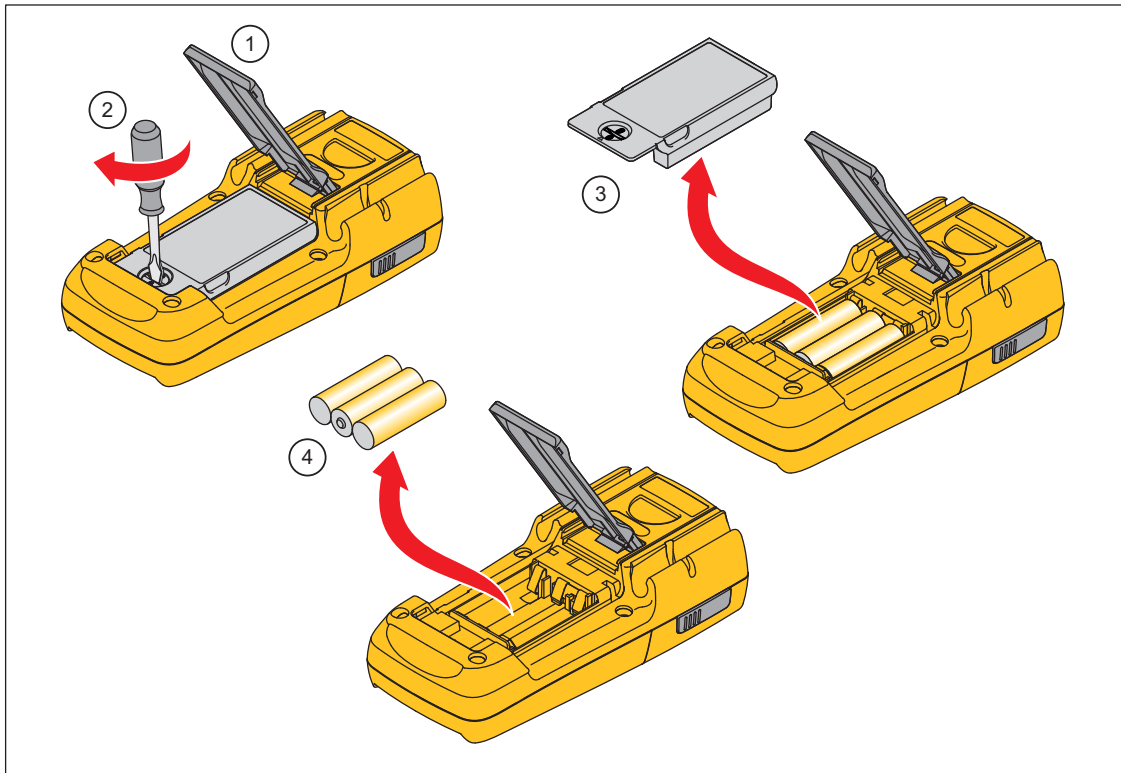

Figure 1. Meter-Base Battery Replacement

gcc112.eps

To replace the batteries in the Meter base:

1. Turn the Meter off and remove all test leads.
2. Lift the tilt stand up as shown in Figure 1.
3. Turn the battery-door latch with a standard screwdriver until the unlocked symbol (🔓) aligns with the arrow.
4. Lift off the battery door.
5. Remove the three AA batteries and replace them with new ones. Use the correct battery orientation.
6. Install the battery door.

Turn the battery-door latch until the locked symbol (🔒) aligns with the arrow. When the Meter does not power on, the Meter-base batteries or display-module batteries can be dead. To find which of the batteries to replace:

1. Dock the display module with the Meter base.
2. Turn the function switch to off and then on.

If the red high-voltage LED on the Meter base flashes, the Meter base batteries are good. Replace the display-module batteries and turn the Meter on.

Remove the Display Module

To remove the display module (see Figure 2):

1. Push in on the latches on the sides of the display module.
2. Pull the display module off of the top end of the Meter base.

The Meter base and display module can be a maximum of 10 Meters (30 feet) from each other before the radio connection is broken. This distance can change if obstacles are between the Meter base and the display module. There is a radio connection between the display module and Meter base when $\left(\left(\frac{\square}{\square}\right)\right)$ shows in the display.

When the display module and Meter base lose the radio connection, the display shows dashes and $\left(\left(\frac{\square}{\square}\right)\right)$ blinks. Possible causes for this loss are the distance is too far for the environment or the batteries in the Meter base are dead. To reconnect, decrease the distance between the display module and Meter base.

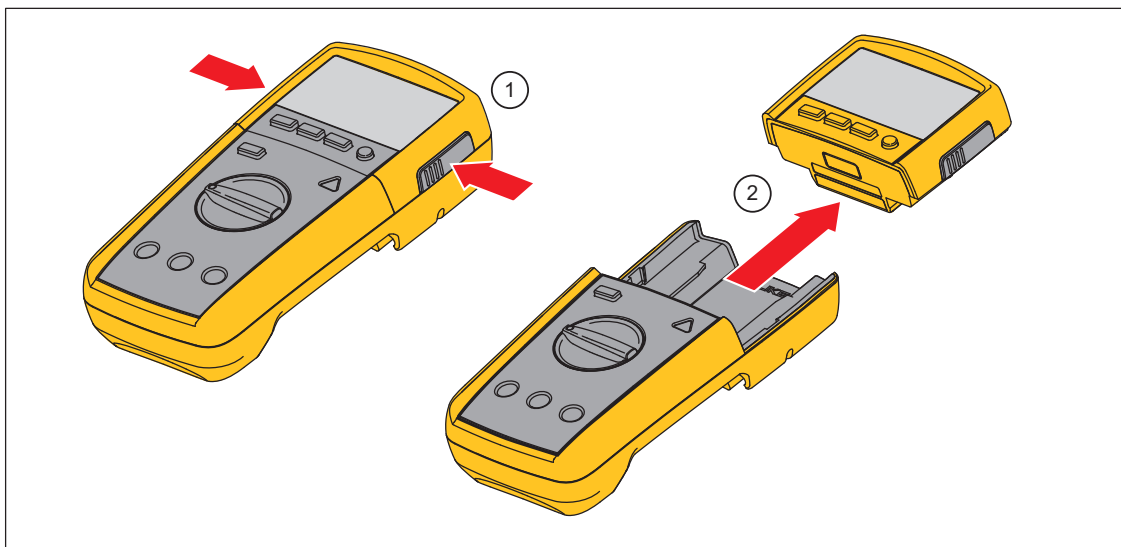

Figure 2. Display Module Separation

gcc114.eps

To replace the batteries in the display module:

1. Remove the display module from the Meter base. See the “Remove the Display” section.
2. Remove the battery door of the display module as shown in Figure 3.
3. Remove the two AA batteries and replace them with new ones. Use the correct battery orientation.
4. Replace the battery door on the display module.

Dock the display module with the Meter base and turn the Meter on.

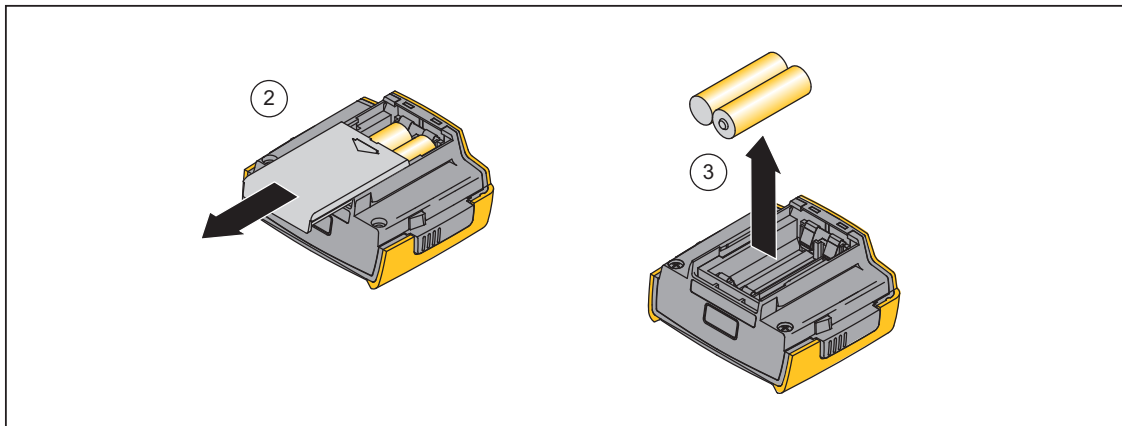

Figure 3. Display-Module Battery Removal

gcc111.eps

Fuse Test

To test the fuse:

1. Set the rotary switch to Ω .
2. Plug a test lead into the Ω jack and touch the probe to the 10A jack, as shown in Figure 0-4.

If the display shows a resistance value in the range of that shown in Figure 0-4, the fuse is good.

If the display reads OL, replace the fuse and test again.

If the display shows any other value, have the Meter serviced. See “Contact Information” earlier in this document.

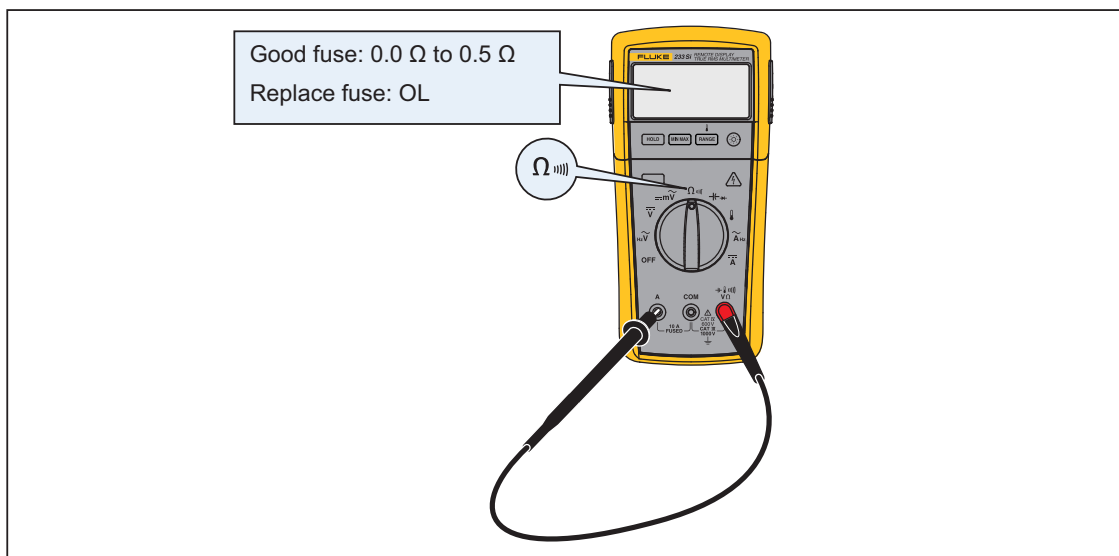

Figure 4. Fuse Test

erc010f.emf

Fuse Replacement

To replace the fuse:

1. Remove the test leads from the Meter.
2. Remove the display module from the Meter base. See the “Remove the Display Module” section.
3. As shown in Figure 5, remove four screws from the case bottom.
4. Pull the case bottom from the case top.
5. Remove the fuse from its holder and replace it with an 11 A, 1000 V, FAST fuse with a minimum interrupt rating of 17,000 A. Use only Fluke PN 803293.

To re-assemble the Meter, do the steps above in the opposite sequence.

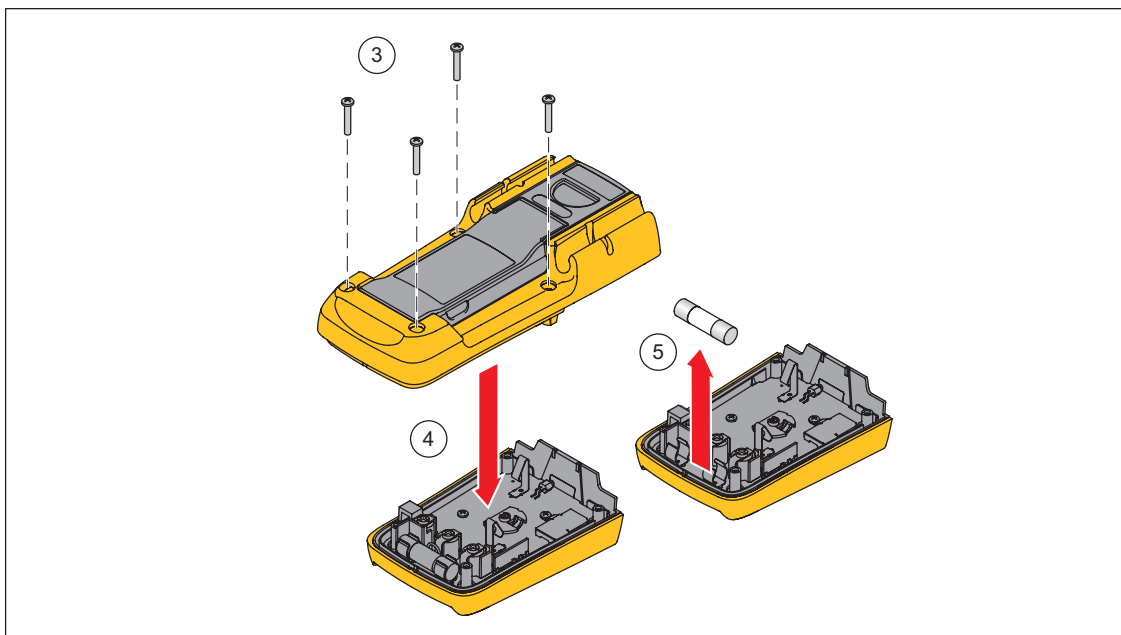

Figure 5. Fuse Replacement

gcc113.eps

Cleaning the Meter

Wipe the case with a damp cloth and mild detergent. Do not use abrasives or solvents. Dirt or moisture in the terminals can affect readings.

Performance Tests

⚠⚠ Warning

To avoid electric shock, do not perform the performance test procedures unless the Meter is fully assembled.

The following performance tests verify the complete operation of the Meter and check the accuracy of each Meter function against its specifications. The recommended calibration interval is 12 months. If the Meter fails any part of the test, calibration adjustment and/or repair is indicated.

In the performance tests, the Meter is referred to as the unit under test (UUT).

Required Equipment

Table 2 lists the equipment required to conduct a performance test on the Meter.

Table 2. Required Equipment

Recommended Equipment	Measurement Function	Accuracy
5500A Multi-product Calibrator (or equivalent)	DC Volts	10 mV to 600 V ±0.0625 %
	DC Current	600 µA to 10 A ±0.25 %
	AC Volts	6 mV to 600 V ±0.25 % @ 45 Hz to 1 kHz
	AC Current	600 µA to 10 A ±0.375 % @ 45 Hz to 1 kHz
	Resistance	0 to 5 MΩ ±0.225 % 10 to 30 MΩ ±0.39 %
	Capacitance	9 to 900 µF ±0.475 %
	Temperature	0 °C to 400 °C ±0.25 %
5500A Multi-product Calibrator (or equivalent)	Frequency	2 V, 50 kHz ±0.025 %
Fluke 80 AK K-type Thermocouple Adapter Accessory	Temperature	
K-type Thermocouple, mini-plug on both ends	Temperature	

Testing the Display

Push **HOLD** and turn the rotary switch to the \tilde{V}^{Hz} position. Compare the display with the example in Figure 6. Check all segments for clarity and contrast.

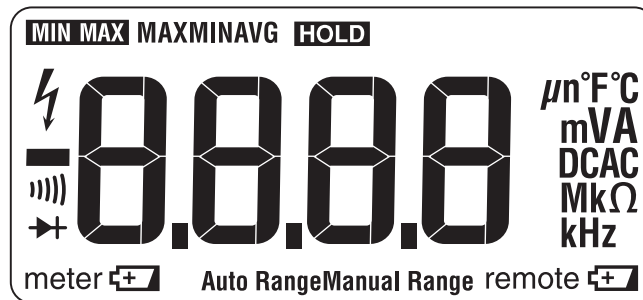

Figure 6. Display Segments

erc022f.emf

Backlight Test

To Test the Backlight, press \odot and verify that the backlight comes on.

Keypad Test

To test the keypad, turn the Meter to ACV and push each button separately. Each button push should cause the Meter to beep and activate a display annunciator.

Reset the Meter by turning it **Off** and then back to an on position.

Preparing for the Performance Tests

$\triangle \triangle$ Warning

To avoid possible electric shock or personal injury:

- Do not perform the following procedures unless qualified to do so. Some procedures involve the use of high voltages.
- Before handling the test connections and in between tests, make sure the calibrator is in standby mode (STBY).

To prepare for the performance test:

1. Make sure that you have the required equipment (refer to Table 2).
2. Warm up the calibrator as required by its specifications.
3. Allow the temperature of the UUT to stabilize at room temperature ($23^{\circ}C \pm 5^{\circ}C$ [$73^{\circ}F \pm 9^{\circ}F$]).
4. Check the fuses and Battery, and replace them if necessary. Refer to “Fuse Test”, and “Fuse Replacement”.

To verify the accuracy of the Meter functions, do the following:

1. Connect the Calibrator to the $V\Omega$ and COM input terminals on the Meter.
2. Turn the rotary switch to the function listed in each step of Table 3.

3. Apply the input level for each step listed in Table 3.
4. Compare the reading on the Meter display with the Display Reading in Table 3.
5. If the display reading falls outside of the range shown in Table 3, the Meter requires calibration adjustment or repair.









Temperature Tests

Connect the K-type thermocouple to the temperature input of the Meter and temperature calibrator. To ensure an accurate measurement, the Meter and the thermocouple connector must be at the same temperature. After connecting the thermocouple to the Meter, allow the junctions to stabilize before recording the displayed reading. This can take several minutes, depending on temperature gradients.

Table 3. Performance Tests

Step	Function	Range	Applied	Display Reading
1	Ω Ohms	600.0	0.0 Ω	0.0 to 0.2
2		600.0	500 Ω	495.3 to 504.7
3		6.000 k	5 k Ω	4.954 to 5.046
4		60.00 k	50 k Ω	49.54 to 50.46
5		600.0 k	500 k Ω	495.4 to 504.6
6		6.000 M	5 M Ω	4.954 to 5.046
7		40.00 M	10 M Ω	9.83 to 10.17
8		40.00 M	30 M Ω	29.53 to 30.47
9	⎓ Continuity	600 Ω	20 Ω	Beeper On
10		600 Ω	250 Ω	Beeper Off
11	\tilde{V} AC Volts	6.000 V	5V, 45 Hz	4.947 to 5.053
12		6.000 V	5V, 1 kHz	4.897 to 5.103
13		60.00 V	50 V, 45 Hz	49.47 to 50.53
14		60.00 V	50V, 1 kHz	48.97 to 51.03
15		600.0 V	600V, 45 Hz	593.7 to 606.3
16		600.0 V	600V, 1kHz	587.7 to 612.3
17		1000 V	1000 V, 500 Hz	977 to 1013
18	\tilde{V} Hz AC Volts + Hz	6.000V	2 v, 50 kHz ^[1]	NA

Table 3. Performance Tests (cont)

Step	Function	Range	Applied	Display Reading
19	 DC Volts	6.000V	0V	-0.002 to 0.002
20		6.000V	5V	4.985 to 5.015
21		60.00V	50V	49.85 to 50.15
22		600.0V	600V	598.3 to 601.7
23		600.0V	-600V	-598.3 to -601.7
24		1000V	1000V	995 to 1000
25	 AC Millivolts	600.0 mV	6 mV, 45 Hz	5.6 to 6.4
26		600.0 mV	600mV, 1 kHz	587.7 to 612.3
27	 DC Millivolts	600.0 mV	20 mV	19.7 to 20.3
28		600.0 mV	600mV	598.3 to 601.7
29	 Diode	2.000 V	1.9V	1.881 to 1.919
31	 Capacitance	1000 nF	30	27 to 33
32			9 μ F	8.81 to 9.19
35			90 μ F	88.1 to 91.9
36			9999 μ F	900 μ F
Set calibrator to standby, reconfigure leads, and program for amps output				
37	 DC Amps	10.00 A	9.5 A	9.37 to 9.63
38	 AC Amps	6.000 A	5.0 A, 45 Hz	4.922 to 5.078
39	 Temperature		Open input	OPEn
40			0.0 °C	-1.0 to 1.0
41			400 °C	395.0 to 405.0

[1] If using a Fluke 9100 calibrator, the Calibrator Frequency mode must be used to obtain accurate frequency.

Calibration Adjustment

The Meter features closed-case calibration adjustment using known reference sources. The Meter measures the applied reference source, calculates correction factors, and stores the correction factors in nonvolatile memory.

The following sections present the features and Meter pushbutton functions available during the Calibration Adjustment Procedure. Should the Meter fail any of the performance tests, perform the Calibration Adjustment Procedure.

Use the following steps to view the Meter's calibration counter.

1. While pressing **HOLD**, turn the rotary switch from **OFF** to **Ω** function. The Meter should display "CAL".
2. Press once to view the calibration counter. For example, "n00 |"

3. Turn the rotary switch to **OFF**.

Calibration Adjustment Password

To start the Calibration Adjustment Procedure, the correct 4-digit password must be entered. The default password is “1234”. The password can be changed or reset to the default as described in following paragraphs.

Changing the Password

Use the following steps to change the Meter’s password:

1. While pressing **HOLD**, turn the rotary switch from **OFF** to Ω function. The Meter should display “ Ω ”.
2. Press once to see the calibration counter.
3. Press again to start the password entry. The Meter displays “????”
4. The Meter buttons indicated below represent the numbers 1 through 5 when entering or changing the password:
HOLD = 1 **MIN MAX** = 2 **RANGE** = 3 = 4  = 5
5. Press 4 buttons to enter the current password. If changing the password for the first time, enter **HOLD** (1), **MIN MAX** (2), **RANGE** (3), and (4).
6. Press **RANGE** to change the password. The Meter displays “????” if the entered password is correct. If the password is not correct, the Meter emits a double beep, displays “????”, and the password must be entered again. Repeat step 5.
7. Press the 4 buttons of the new password.
8. Press to store the new password.

Restoring the Default Password

If the calibration password is forgotten, the default password (1234) can be manually restored using the following steps:

Warning

To avoid electric shock or personal injury, remove the test leads and any input signal before removing the Meter’s back case.

1. Remove the Meter’s back case. Leave the PCA in the top case.
2. Apply 4.5 V across the battery contacts (XBT1) + and (XBT2) – on the back of the PCA. See Figure 7.
3. Turn the rotary switch from **OFF** to any on position.
4. Short across the S103 CAL keypad on the back of the PCA. See Figure 7. The Meter should beep. The default password is now restored.
5. Remove the 4.5 V supply and replace the Meter’s back case.

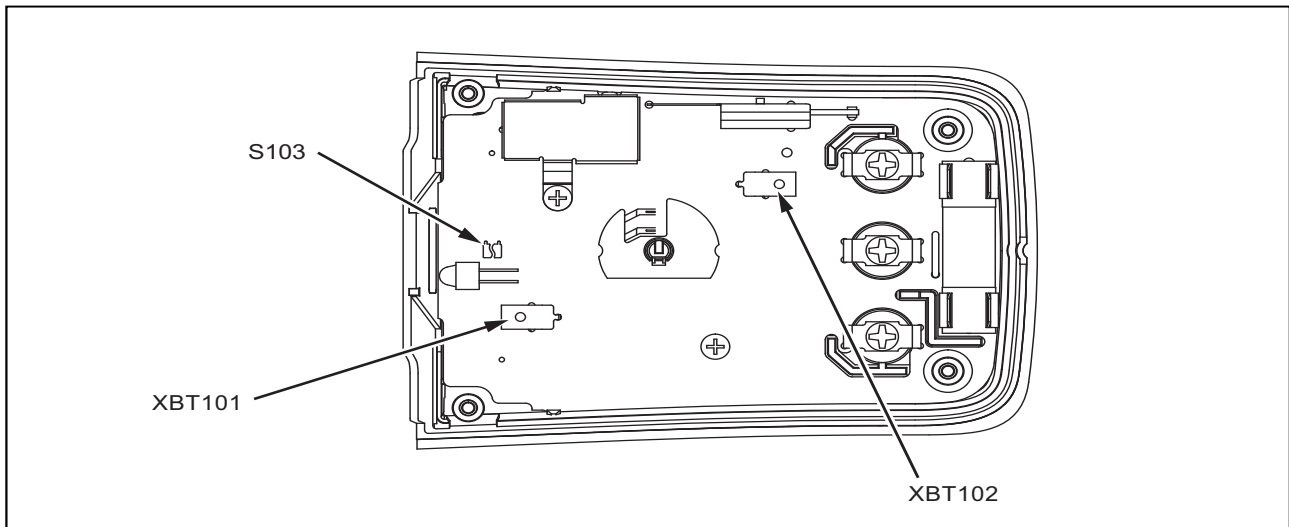



Figure 7. Calibration Password Reset

erc12f.emf

Meter Buttons Used in the Calibration Steps

When performing the Calibration Adjustment Procedure, the Meter buttons behave as follows. This may be of help in determining why a calibration step is not accepted and for determining the input value without referring to Table 4.

1. Press and hold **HOLD** to show the measured value. The measured value is not calibrated so it may not match the input value. This is normal.
2. Press and hold **MIN MAX** to display the required input value.
3. Press to store the calibration value and advance to the next step. This button is also used to exit calibration mode after the calibration adjustment sequence is complete.
4. Press  to toggle the backlight on and off.

Calibration Adjustment Procedure

To adjust the Meter's calibration, use the following steps:

Note

If the Meter is turned off before completion of the adjustment procedure, the calibration constants are not changed.

1. While holding down **HOLD**, turn the rotary switch from **OFF** to Ω function. The Meter should display "RL".
2. Press once to see the calibration counter.
3. Press again to start the password entry. The Meter displays "????".
4. Press the 4 button password.
5. Press to go to the first calibration step. The Meter displays "[-0]" if the password is correct. If the password is not correct, the Meter emits a double beep, displays "????", and the password must be entered again. Repeat step 4.
6. Apply the input value listed for each calibration adjustment step. For each step, select the rotary switch position and apply the input to the terminals as indicated in the Table 4.

Note

Some adjustment steps require additional wait time after the calibrator settles, as noted in Table 4.

7. After each input value is applied, press to accept the value and proceed to the next step (F-02 and so forth).

Notes

After pressing , wait until the step number advances before changing the calibrator source or turning the Meter's rotary knob. Some adjustment steps can take up to several seconds to execute before moving to the next step.

If the knob is not in the correct position for a given step, the meter will flash the unit annunciators until the knob is put in a valid position. The keys that show the reading and required input values are not allowed until the knob is correct.

Likewise, if the rotary switch is not in the correct position or the measured value is not within the anticipated range of the input value, the Meter will emit a double beep and will not continue to the next step when is pressed.

8. After the final step, the display shows "End" to indicate that the calibration adjustment is complete. Press to return to meter mode.

Notes

Set the calibrator to Standby prior to changing the function switch position and after completing adjustment of each function.

If the calibration adjustment procedure is not properly completed, the Meter will not operate correctly.

Table 4. Calibration Adjustment Steps



Rotary Switch Position	Calibration Steps	Input Terminals	Calibrator Source Value
\tilde{mV}	[-01]	V Ω /+ and COM	0 V, 0 Hz
	[-02]	V Ω /+ and COM	300 mV, 0 Hz
	[-03]	V Ω /+ and COM	100 mV, 0 Hz
	[-04]	V Ω /+ and COM	-300 mV, 0 Hz
	[-05]	V Ω /+ and COM	60 mV, 0 Hz
	[-06]	V Ω /+ and COM	600 mV, 0 Hz
	[-07]	V Ω /+ and COM	600 mV, 60 Hz
Ω Ohms	[-08]	V Ω /+ and COM	600 Ω , 2-wire comp
	[-09]	V Ω /+ and COM	6 k Ω
	[-10]	V Ω /+ and COM	60 k Ω
	[-11]	V Ω /+ and COM	600 k Ω
	[-12]	V Ω /+ and COM	6 M Ω ^[1]
	[-13]	V Ω /+ and COM	Short ^[1]
	[-14]	V Ω /+ and COM	40 M Ω ^[1]
\tilde{V}	[-15]	V Ω /+ and COM	6 V, 60 Hz
	[-16]	V Ω /+ and COM	60 V, 60 Hz
	[-17]	V Ω /+ and COM	600 V, 60 Hz
	[-18]	V Ω /+ and COM	6 V, 0 Hz
	[-19]	V Ω /+ and COM	60 V, 0 Hz
	[-20]	V Ω /+ and COM	600 V, 0 Hz
Set calibrator to standby, reconfigure leads, and program for amps output.			
\tilde{A}	[-22]	A and COM	6 A, 60 Hz ^[1]
\overline{A}	[-23]	A and COM	6 A, 0 Hz

[1] Wait an additional 5 seconds after calibrator has settled before pressing .

Replacement Parts

Table 5 lists the Meter's replaceable parts identified in Figure 8.

Table 5. Replaceable Parts

Item	Description	Part Number	Qty.
BT1 BT2 BT3 BT4 BT5	BATTERY,PRIMARY,ZN-MNO2,1.5V,2.24AH,15A,LR6,ALKALINE,AA,14X50MM,BULK	376756	5
F1 	FUSE,11A,1000V,FAST.406INX1.5IN,BULK	803293	1
H1 H2 H3 H4 H5 H6	SCREW,5-14,.750,PAN,PHILLIPS,STEEL,BLACK (Case Screws) CHROMATE,THD FORMING	832246	6
H7 H8 H9 H10	SCREW,4-14,.375,PAN,PHILLIPS,STEEL,ZINC-ROHS CLEAR,THREAD FORM	448456	4
MP1	FLUKE-233-2003,CASE TOP, DISPLAY	3383743	1
MP2	LCD RDX	3385697	1
MP3	FLUKE-233-8004,BACKLIGHT DIFFUSER	3385715	1
MP4	FLUKE-233-8008,KEYPAD, DISPLAY	3383900	1
MP5 MP6	FLUKE-233-8003,SPRING LATCH	3383917	2
MP7	FLUKE-233-2501,MASK PAD XFER	3383820	1
	FLUKE-233-2501-01,MASK PAD XFER SI (Japan)	3470114	1
MP8	FLUKE-233-2008,BUTTON, LATCH, RIGHT	3383796	1
MP9	FLUKE-233-2008-01,BUTTON, LATCH, LEFT	3383801	1
MP10	FLUKE-233-2006,BATTERY DOOR, DISPLAY	3383770	1
MP11	FLUKE-233-2004,CASE BOTTOM, DISPLAY	3383755	1
MP12	CONNECTOR,ELASTOMERIC,.010 IN CTR,.218 IN HIGH,.090 IN THK,2.284 IN LONG,BULK	2534229	1
MP13	FLUKE 89-4-8012 ,BATTERY CONTACT, DUAL	666435	3
MP14	FLUKE-233-2503,CASE TOP, MAIN PAD XFER	3476126	1
MP15	FLUKE-15X7-8008,KNOB	2278007	1
MP16	FLUKE-15X7-8010,DETENT SPRING	2278029	1
MP17	FLUKE-233-8002,KEYPAD, MAIN	3383886	1
MP18	FLUKE-233-8001,SHIELD, RSOB	3383858	1
MP19	FLUKE-15X7-8009,HOUSING ASSY,RSOB	2278018	1
MP20	FLUKE 87-8004 ,CONTACT,PTF	822676	1
MP21	FLUKE-233-2002,CASE BOTTOM,MAIN	3383737	1
MP22	FLUKE-233-2005,BATTERY DOOR, MAIN	3383762	1
MP23	SCREW,M3-0.5X5MM,PHILLIPS PAN HEAD,DIN 7985, STEEL,ZINC,METRIC MACHINE SCREW (Input terminal screws)	3498942	3
MP24	FLUKE-233-8009,SHIELD,LEO	3451924	1
TM3	MANUAL,MAUAL INFO PACK,FLUKE-233	3474766	1
 To ensure safety, use exact replacement only.			

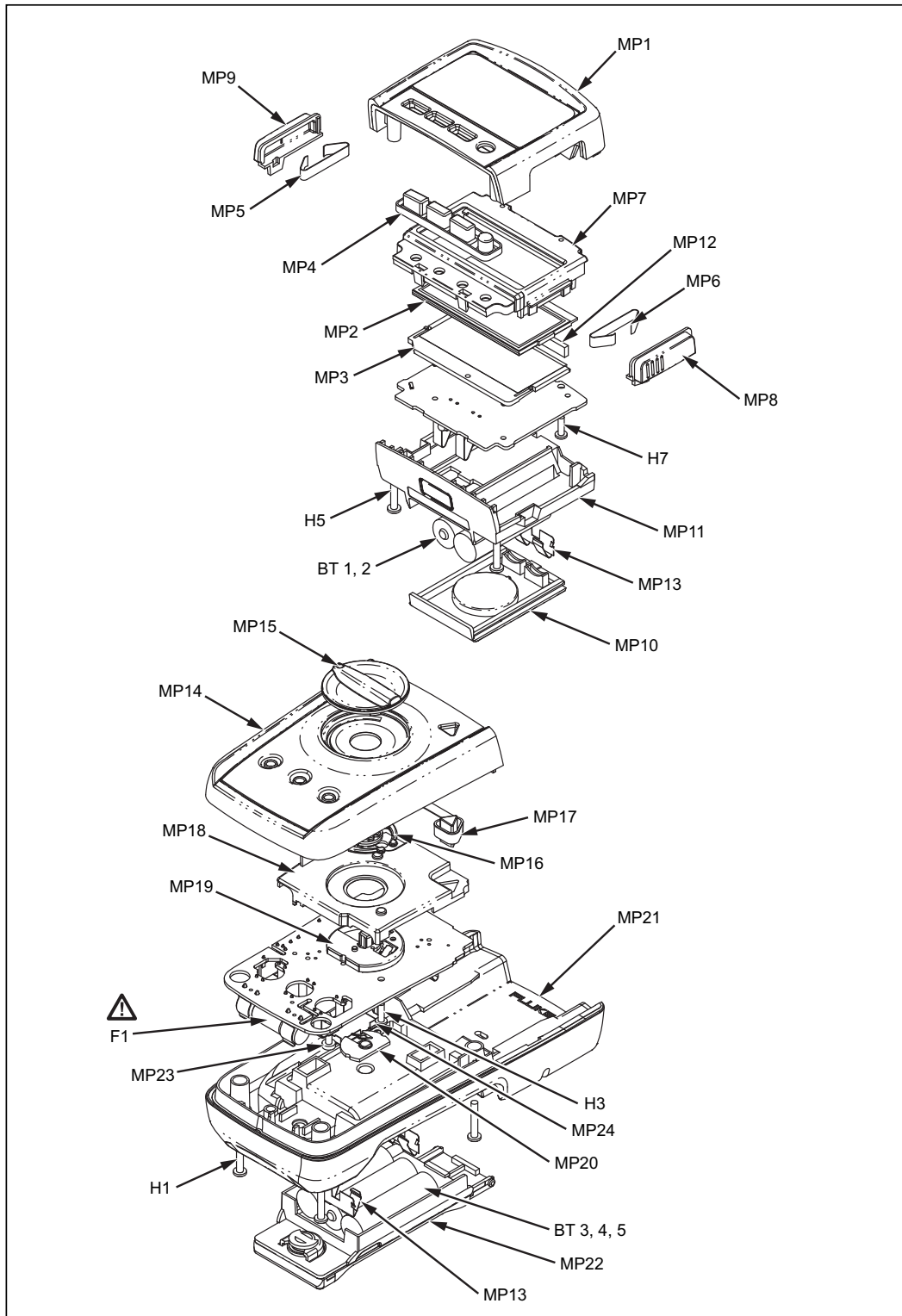

Figure 8. Replaceable Parts

Warranty

This Fluke product will be free from defects in material and workmanship for three years from the date of purchase. This warranty does not cover fuses, disposable batteries, or damage from accident, neglect, misuse, alteration, contamination, or abnormal conditions of operation or handling. Resellers are not authorized to extend any other warranty on Fluke's behalf. To obtain service during the warranty period, contact your nearest Fluke authorized service center to obtain return authorization information, then send the product to that Service Center with a description of the problem.

THIS WARRANTY IS YOUR ONLY REMEDY. NO OTHER WARRANTIES, SUCH AS FITNESS FOR A PARTICULAR PURPOSE, ARE EXPRESSED OR IMPLIED. FLUKE IS NOT LIABLE FOR ANY SPECIAL, INDIRECT, INCIDENTAL OR CONSEQUENTIAL DAMAGES OR LOSSES, ARISING FROM ANY CAUSE OR THEORY. Since some states or countries do not allow the exclusion or limitation of an implied warranty or of incidental or consequential damages, this limitation of liability may not apply to you.

Fluke Corporation
P.O. Box 9090
Everett, WA 98206-9090
U.S.A.

Fluke Europe B.V.
P.O. Box 1186
5602 BD Eindhoven
The Netherlands

11/99

