

Minivent Series – MV132E

Location

Project

Designation

Notes

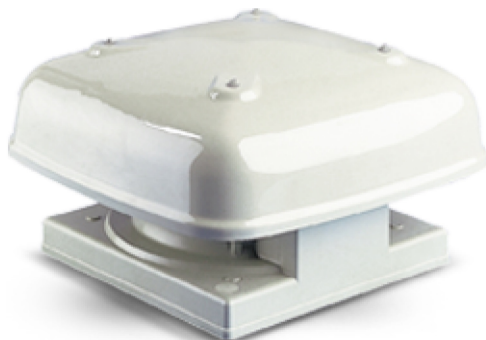

Features

The Minivent Series of axial roof units has been specifically developed to meet the airflow requirements of small to medium sized rooms. Applications range from domestic to commercial.

Construction

Cowls are of UV-stabilised plastic.
Steel components have a corrosion-resistant finish.

Motors

Type - external rotor, squirrel cage induction motor.
Electricity supply - 220-240V, single-phase, 50/60Hz.
Bearings - sealed-for-life, ball.
Speed-controllable except MV112 and MV132.

Internal Thermal Protection

MV112 and MV132 are impedance protected
MV202 and above are fitted with auto-reset thermal contacts as standard.

Testing

Air flow tests to BS848:Part 1, 1980.
Noise tests to BS848:Part 2, 1985.

Note

Backdraft shutters can only be fitted to sizes 252/4 and 302/4 and butterfly shutters to size 354. When used, derate the fan performance by 15-20%.

Special Features

Can be mounted at angles up to 30°.
Supply air units can be supplied.

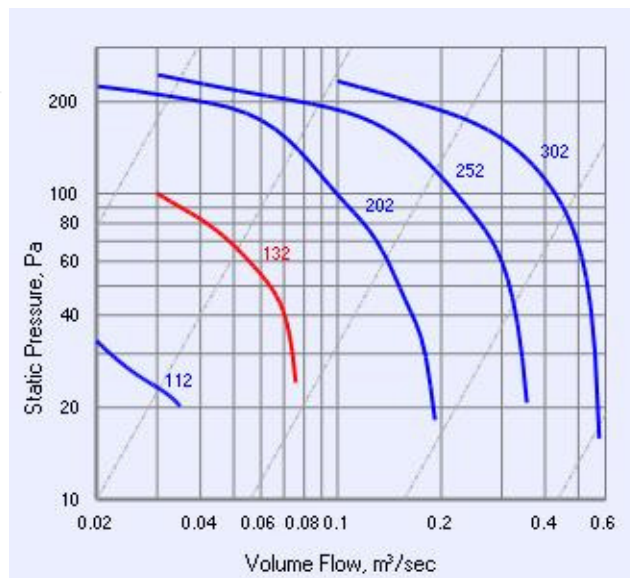

Technical Data - MV132E

Speed [rps]	Avg. dBA @ 3m	kWatts (Input)	Amps	Max.° C	Approx. Weight [kg]
47	43	0.046	0.3	80	1.9

Sound Data

Type	63	125	250	500	1K	2K	4K	8K
Inlet	51	51	59	55	57	58	56	

Minivent Series – MV132E

Suggested Specification

The roof ventilators shall be of the Minivent Series as designed and manufactured by Fantech Pty. Ltd.

The axial impellers shall be driven by speed-controllable external rotor motors with integral thermal protection.

The cowl shall be of UV-stabilised plastic with built-in terminal box.

All models shall be fully tested to BS848:Part 1, 1980 for air flow and BS848:Part 2, 1985 for noise.

Dimensions

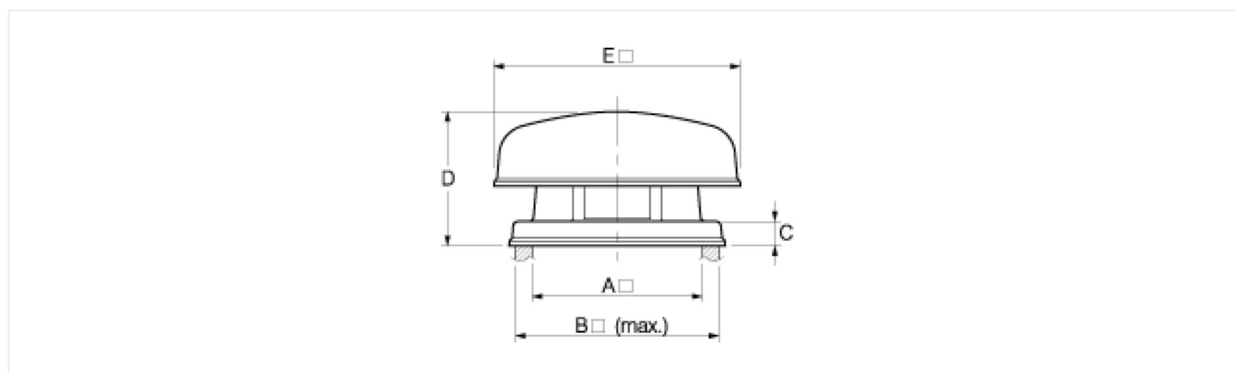

A	B	C	D	E
210	260	30	200	310

All dimensions in mm, unless otherwise stated

Contacts



OFFICES & AGENTS

Victoria

Fantech Pty. Ltd.
Tel:+61 (03) 9554-7845

New South Wales

Fantech Pty. Ltd.
Tel:+61 (02) 8811-0400

Uniair Distributors Pty. Ltd.

Tel:+61 (02) 4961-6088
Refrigeration and Air Supplies
Tel:+61 (02) 4226-5133
Fantech Pty. Ltd.
Tel:+61 (02) 6025-1866

South Australia

Fantech Pty. Ltd.
Tel:+61 (08) 8294-0530

Queensland

Air Design Pty. Ltd.
Tel:+61 (07) 3299-9888
Capricorn Air Conditioning
Tel:+61 (07) 4775-5222

Northern Territory **Fantech Pty. Ltd.**

Tel:+61 (08) 8947-0447

Western Australia **Systemaire Pty. Ltd.**

Tel:+61 (08) 9209-4999

Tasmania

Major Air Pty. Ltd.
Tel:+61 (03) 6344-6888
Hobart
Tel:+61 (03) 62736455

ACT

Idealair Group Pty. Ltd.
Tel:+61 (02) 6280-5511

Auckland

Fantech (NZ) Ltd.
Tel:+64 (09) 444-6266

Christchurch

Fantech (NZ) Ltd.
Tel:+64 (03) 379-8622

Wellington

Fantech (NZ) Ltd.
Tel:+64 (04) 566-0532