

PTD-BRK/FS-1A

Powered Current Sensing Trip Amplifier – Brake Motors



GENERAL DESCRIPTION

The PTD-BRK/FS is a fully isolated dual trip amplifier/alarm module that accepts an AC or DC current input from 0 Amp up to 1 Amps from up to a 415V supply line. *** A separate 2 Amp version is also available

The PTD-BRK/FS provides a trip relay output which operates between the fixed “Base” and “Maximum” current setting. It works as a stand-alone alarm unit and operates as a window comparator where the relay de-energises if the signal goes below 60mA or above 500mA. The relay has a fixed dead-band of 20%.

FEATURES

- ◆ Wide Operating Voltage Range
- ◆ Set Point Trip Status LED's
- ◆ Trip window factory set with status LED's
- ◆ Very small footprint area
- ◆ DIN & G rail mounting style
- ◆ Low power consumption
- ◆ 600V HBC 3.15A Input Protection Fuse

TECHNICAL DATA

Power Supply.
 Nominal Supply 22V - 60Vac/dc
 VA Rating Typically 1.2VA
 Max Power Typically 1.3VA with relay energised.

Input (Internally Fuse Protected 3.15A SIBA 189-020)
 Amps AC or DC 0 Amp to 1Amps (Terms 1-3)

Base Current (1A) 60mA to 500mA

Volts (max) 500Vac/300Vdc on terms 1 & 3
 Input Resistance < 0.1 Ohm

Output (Single relay c/o output)
 Set Point Relay c/o contact
 Under Current and/or Over Current fixed set points.
 For 0 – 1Amp 0– 10Vdc (1A = 10V)

GENERAL SPECIFICATION

Accuracy 2.5% of span
 Linearity 1% of span
 Response time 0 to 110% step in 1.5 sec
 Drift 0.25% per Deg C
 Isolation level Greater than 500Vrms
 Dead Band Fixed at 20% of relay set.
 Trip Settings Under Current - 50% of Base
 Over Current + 50% of Base
 Trip Status 2 x Red,
 Fuse Status 1 x Yellow LED
 Power Status 1 x Blue LED

Output Relay
 Contact Configuration 1 Form C (SPDT)
 Max Voltage Up to 220 Vdc or 250 Vac
 Max Power Rating 30 Watts or 62.5 VA
 Max Cont. Current 2 Amps (non-inductive)
 Vibration 20G
 Shock 75G
 Life Expectancy Mechanical 10 x 10⁶

Mechanical
 Operating Temp 0 to 60 Deg C
 Store Temp -25 to +75 Deg C
 Mounting Style DIN & G Rail
 Terminals 2.5mm² / 12AWG
 Housing Material KRILEN
 Dimensions 79 x 106 x 25mm wide
 Weight 110 grams

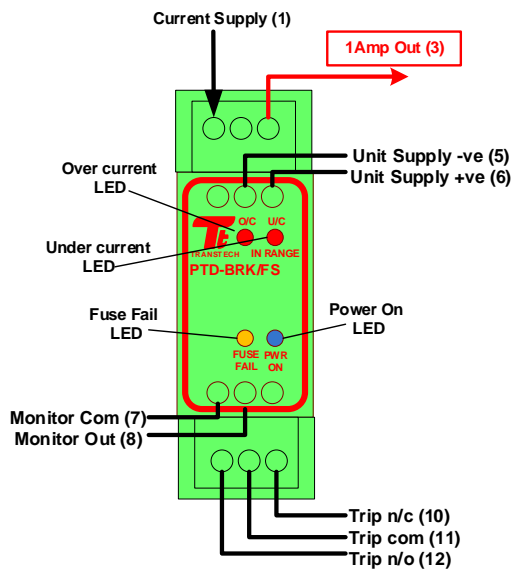

CONNECTION DIAGRAM

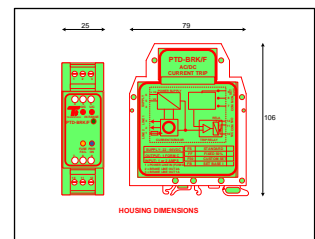

PTD-BRK/FS-1A

Powered Current Sensing Trip Amplifier – Brake Motors

IMPORTANT

1. THERE ARE NO INTERNAL SETTINGS REQUIRED IN THE FIELD.

2. AT VERY LOW CURRENT SETTINGS THE PTD-BRK/F MAY BE AFFECTED BY NOISE INTERFERENCE.

3. IMPORTANT NOTE:

If supply is removed to the PTD-BRK the Fuse Fail LED will be reset.

RELAY OPERATION

The relay is set to be “normally energised”, that is when DC power is applied to the PTD and the signal is above the lower trip point and below upper trip point; the relay is energised. If the power supply goes off or the signal is above or below the set points (fault) the relay will de-energise.

CALIBRATION & SET-UP INSTRUCTIONS:-

PTD-BRK/FS-1A & PTD-BRK/FS-2A (Standard version – factory set).

From Nov 2013 the trip settings are as below:

For the **1Amp version** the low trip is set to 60mA and the high trip is set to 500mA
For the **2Amp version** the low trip is set to 120mA and the high trip is set to 1000mA.

Top decade switches masked off – **DO NOT ADJUST**

Other PTD-BRK/FF versions are:

PTD-BRK/FF-1A and PTD-BRK/FF-2A (Fixed threshold set to +/- 50% of base I)

Turn the fine decade switch to zero (0) and coarse switch to nine (9) Link terminals 7 – 9

With a load connected and the “In Range” Green LED on adjust the coarse decade switch slowly down (anti-clock) until the LED goes off.

Now adjust the fine decade switch slowly up (clockwise) until the Green LED comes on – the base current is now set.

Remove the link between terminals 7 – 9

NOTES:-

1. The sensed current can be measured by connecting a DVM ranged 0 – 10VDC between terminals 7 and 8.
2. The base current is set by a combination of:
 - Input current (either 0-1 or 0-2 amp)
 - Top of panel switches (coarse and fine) where:
 - Coarse = 10% of range | Fine = 1% of range.

For other modes of operation consult factory.