

## PTD-BRK/FF

### Powered Current Sensing Trip Amplifier (field settable) for Brake Motors



#### GENERAL DESCRIPTION

The PTD-BRK/FF is a fully isolated dual trip amplifier/alarm module that accepts an AC/DC current input from 0 Amp up to 2 Amps from up to a 415V supply line.

The PTD-BRK/FF provides an adjustable trip relay output. The relay is normally energised and trips on both Hi and Lo alarm conditions. The 'Base' current is set by two front panel adjustment switches with the standard unit having set points fixed at +50% and -50% of the Base current.

The PTD-BRK/FF is a stand-alone alarm unit and operates as a window comparator where the relay de-energises if the signal goes outside either the Lo or Hi settings. The relay has a fixed dead-band of 20%.

#### FEATURES

- ◆ Wide Operating Voltage Range
- ◆ Set Point Trip Status LED's
- ◆ Trip window set by the 2 front panel selector switches and status LED's
- ◆ Very small footprint area
- ◆ DIN & G rail mounting style
- ◆ Low power consumption
- ◆ 600V HBC 3.15A Input Protection Fuse

#### TECHNICAL DATA

##### Power Supply.

Nominal Supply	22V - 60Vac/dc
VA Rating	Typically 1.2VA
Max Power	Typically 1.3VA with relay energised.

##### Input (Internally Fuse Protected 3.15A SIBA 189-020)

Amps AC or DC	0 Amp to 1Amps (Terms 1-3) 0 Amp to 2Amps (Terms 1-2)
Base Current (1A)	50mA to 500mA
Base Current (2A)	120mA to 1000mA
Volts (max)	500Vac/300Vdc on terms 1 & 3
Input Resistance	< 0.1 Ohm

##### Output (Single relay c/o output)

Set Point	Relay c/o contact Under Current and/or Over Current fixed set points.
For 0 – 1Amp	0– 10Vdc (1A = 10V)

#### GENERAL SPECIFICATION

Accuracy	2.5% of span
Linearity	1% of span
Response time	0 to 110% step in 1.5 sec
Drift	0.25% per Deg C
Isolation level	Greater than 500Vrms
Dead Band	Fixed at 20% of relay set.
Trip Settings	Under Current - 50% of Base Over Current + 50% of Base
Trip Status	2 x Red, 1 x Green LEDs
Fuse Status	1 x Yellow LED
Power Status	1 x Blue LED

##### Output Relay

Contact Configuration	1 Form C (SPDT)
Max Voltage	Up to 220 Vdc or 250 Vac
Max Power Rating	30 Watts or 62.5 VA
Max Cont. Current	2 Amps (non-inductive)
Vibration	20G
Shock	75G
Life Expectancy	Mechanical 10 x 10 <sup>6</sup>

##### Mechanical

Operating Temp	0 to 60 Deg C
Store Temp	-25 to +75 Deg C
Mounting Style	DIN & G Rail
Terminals	2.5mm <sup>2</sup> / 12AWG
Housing Material	KRILEN
Dimensions	79 x 106 x 25mm wide
Weight	110 grams

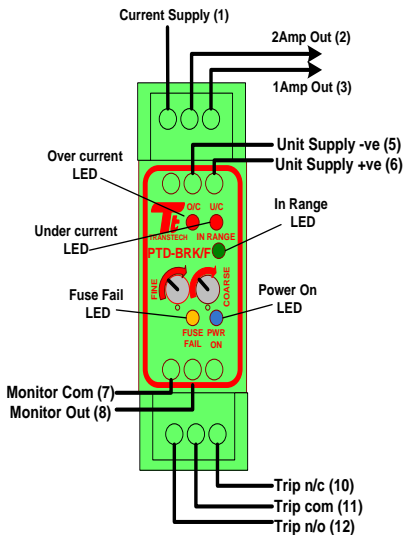

CONNECTION DIAGRAM

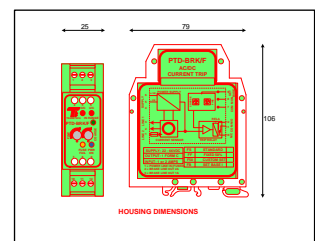

## PTD-BRK/FF

### Powered Current Sensing Trip Amplifier (field settable) for Brake Motors

#### IMPORTANT

1. THERE ARE NO INTERNAL SETTINGS REQUIRED IN THE FIELD.

2. THE BASE CURRENT HI AND LO TRIPS ARE BY “FRONT OF PANEL” 9 POSITION DECADE SWITCHES ALLOWING FOR SETTINGS TO BE RECORDED.

3. AT VERY LOW CURRENT SETTINGS THE PTD-BRK/F MAY BE AFFECTED BY NOISE INTERFERENCE.

4. **IMPORTANT NOTE:**  
If supply is removed to the PTD-BRK the Fuse Fail LED will be reset.

#### RELAY OPERATION

The relay is set to be “normally energised”, that is when DC power is applied to the PTD and the signal is above the lower trip point and below upper trip point; the relay is energised. If the power supply goes off or the signal is above or below the set points (fault) the relay will de-energise.

#### CALIBRATION & SET-UP INSTRUCTIONS:-

The PTD-BRK/F comes in four (4) versions as listed below:-

##### PTD-BRK/FF (Fixed threshold set to +/- 50% of base I)

Turn the fine decade switch to zero (0) and coarse switch to nine (9) Link terminals 7 – 9 With a load connected and the “In Range” Green LED on adjust the coarse decade switch slowly down (anti-clock) until the LED goes off. Now adjust the fine decade switch slowly up (clockwise) until the Green LED comes on – the base current is now set. Remove the link between terminals 7 – 9

NOTE: The Over Current setting is link selectable internally and can be disconnected.

##### Other PTD-BRK/F versions are:

##### PTD-BRK/FS (Standard version – factory set).

Low set to 50mA / High set to 500mA (for 1Amp connection)  
NOTE: If the 2Amp connection is selected then it is 200mA and 1000mA  
Top decade switches masked off – **DO NOT ADJUST**

##### PTD-BRK/F50 (Factory set to a % internally other than 50% of base I)

Same field set up as per model PTD-BRK/FF

##### PTD-BRK/FB (Special mode type low threshold independent of base I)

The Lo set is specified by the customer and factory fixed internally  
The Hi is set by the front panel switches with Std deadband = 20%  
Set up as per field setup per PTD-BRK/FF (sets only the HI limit).

##### NOTES:-

- The sensed current can be measured by connecting a DVM ranged 0 – 10VDC between terminals 7 and 8.
- The base current is set by a combination of:  
Input current (either 0-1 or 0-2 amp)  
Top of panel switches (coarse and fine) where:  
Coarse = 10% of range | Fine = 1% of range.

For other modes of operation consult factory.

MSD (COURSE)			LSD (FINE)		
RANGE (AMPS)			RANGE (AMPS)		
POSITION	1A	2A	POSITION	1A	2A
0	0.0	0.0	0	0.00	0.00
1	0.1	0.2	1	0.01	0.02
2	0.2	0.4	2	0.02	0.04
3	0.3	0.6	3	0.03	0.06
4	0.4	0.8	4	0.04	0.08
5	0.5	1.0	5	0.05	0.10
6	0.6	1.2	6	0.06	0.12
7	0.7	1.4	7	0.07	0.14
8	0.8	1.6	8	0.08	0.16
9	0.9	1.8	9	0.09	0.18

SETPOINT OUTPUT IS MSD + LSD

##### EXAMPLES:-

FF UNIT SET CURRENT 270mA FOR 0-1A RANGE  
MSD = 2 (0.2A) & LSD = 7 (0.07A) => 270mA  
LOWER THRESHOLD = 135mA (-50%) & UPPER THRESHOLD = 405mA

FF UNIT SET CURRENT 1.15A FOR 0-2A RANGE  
NEAREST SETABLE VALUE EITHER 1.14A OR 1.16A  
MSD = 5 (1.0A) & LSD = 7 (0.14A) => 1.14A  
LOWER THRESHOLD = 0.57A (-50%) & UPPER THRESHOLD = 1.71A  
OR  
MSD = 5 (1.0A) & LSD = 8 (0.16A) => 1.16A  
LOWER THRESHOLD = 0.58A (-50%) & UPPER THRESHOLD = 1.74A